

TRICARGO 200



Catálogo de partes



www.autecomobility.com Línea gratuita nacional : 01 8000 413 812



ANEXO INFORMACIÓN DE SEGURIDAD

Verifique la carátula de este manual para conocer cuál de los siguientes dispositivos de seguridad posee su vehículo.



SISTEMA ANTIBLOQUEO DE FRENOS

Sistema diseñado para evitar que las ruedas se bloqueen al frenar de forma brusca mientras se circula en línea recta, el sistema regula automáticamente la fuerza de frenado.

Aunque el sistema ABS proporciona estabilidad al detenerse, recuerde las siguientes características:

- * Para frenar de forma eficaz, deje de acelerar y utilice la leva de freno delantero y el pedal de freno trasero simultáneamente, de la misma manera que en el sistema de frenos de una motocicleta convencional
- * El ABS no puede compensar las condiciones adversas de la carretera, un error de juicio o un uso incorrecto de los frenos.



SISTEMA DE ENCENDIDO AUTOMÁTICO DE LUCES (AHO)

Sistema diseñado para que una vez se ponga el motor en marcha, la luz principal de la farola se encienda automáticamente.

Este sistema garantiza una mayor visibilidad del vehículo para los demás actores viales.



SISTEMA DE LUCES DE CIRCULACIÓN DIURNA (DRL)

Sistema de iluminación LED, el cual se enciende automáticamente al girar el interruptor de encendido a "ON".

Mientras la farola principal esté apagada, la luz LED alumbrará intensamente, si se enciende la farola principal, la luz LED se atenuará automáticamente.

No se recomienda dejar el interruptor de encendido en "ON" mientras el motor no esté en funcionamiento porque la batería se drenará prematuramente.

Advierta lo que le dicen las llantas mientras conduce:

- Si su respuesta a la dirección es lenta o si en las curvas y en el frenado la respuesta es pesada, es muy probable que sus llantas estén desinfladas.
- Vibración o tambaleo durante la conducción, puede significar que la presión en las llantas es mayor a la recomendada, o que ha ocurrido un daño en la llanta y la falla es inminente.
- La llanta puede vibrar a ciertas velocidades debido al desbalanceo, en este caso su desgaste será muy acelerado.

**RECUERDE SIEMPRE REVISAR LA PRESIÓN DE AIRE EN SUS LLANTAS
ANTES DE COMENZAR A RODAR**

PREFACIO

Es nuestro placer presentarles a ustedes el Catálogo de Partes.

Este Catálogo ha sido especialmente diseñado para ayudarle en la selección de las partes correctas con el fin de mantener el vehículo en las mejores condiciones.

Los repuestos originales están sujetos a un exigente estándar de control de calidad, por lo tanto es necesario que usted sólo use repuestos originales.

En nuestro constante esfuerzo para mejorar la eficiencia y desempeño de su vehículo, las especificaciones, diagramas y número de partes pueden cambiar sin previo aviso. Consecuentemente las descripciones de los repuestos en este Catálogo pueden no ser las finales y definitivas.

Las alteraciones y modificaciones que ocurren en la impresión de este Catálogo, serán informadas a nuestra red, a través de circulares de Servicio o en nuestra página web: www.auteco.com.co accediendo al link repuestos. Es requisito que usted actualice su Catálogo y haga las correcciones necesarias, una vez reciba dichas circulares. Lo anterior le asegurará un rápido y adecuado despacho de sus partes, pues las órdenes están siendo diligenciadas con las referencias más actualizadas.

En caso de necesitar asistencia técnica, comunicarse con el Distribuidor Autorizado o llamar al Departamento de Servicios Auteco.

Mobil Super™

4T Ultra

Aceite de alto desempeño para motores de cuatro tiempos



GRADO
SAE

20W-50

**CUMPLE CON LAS
NORMATIVAS**

JASO MA
JASO MA2
API SL



CÓDIGO SAP:

CAJA X 12
21010428

UNIDAD
21010430



PROPIEDADES BENEFICIOS &



- **Buena protección contra el desgaste**
Ayuda a prolongar la vida útil del motor.
- **Estabilidad térmica y contra la oxidación**
Ayuda a mantener los motores limpios para proporcionar una operación más suave, posibilitando la extensión de frecuencia de cambios de aceite.
- **Buena protección contra la corrosión**
Protege los componentes críticos del motor contra los ácidos de la combustión y la humedad.



Recomendado para las motocicletas
con viscosidad **20W-50**

El amor por tu motor ahora es **AMARILLO** con la

NUEVA TECNOLOGÍA
DURAFILM



**¡POR DESEMPEÑO,
CALIDAD Y PRECIO!**

ELIGE LLANTAS QUEEN

SCOOTER

MOTOCARRO

STREET

DOBLE
PROPÓSITO

PISTERA



Encuétralos en todos los agentes y concesionarios autorizados por AUTECO del país



MEGA  **BAT**
BATTERIES



EL EQUIPO ORIGINAL
DE LAS MOTOCICLETAS

auteco
mobility

*Una garantía de respaldo,
calidad y experiencia.*

ÍNDICE DE GRÁFICOS



FIGURA N° 1: CULATA - CARBURADOR

PÁG. N°.
1

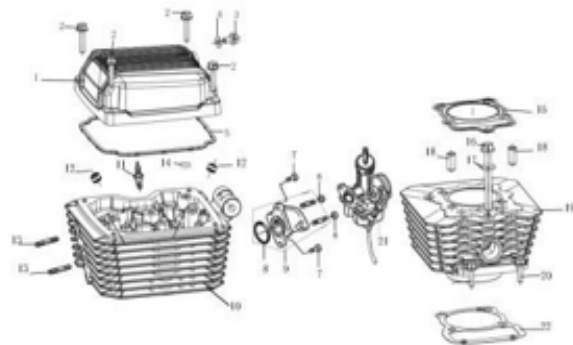

FIGURA N° 2: EJE LEVAS - VÁLVULAS

PÁG. N°.
2

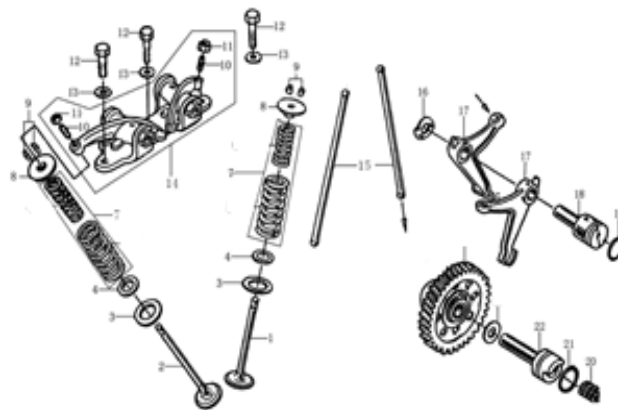

FIGURA N° 3: CUBIERTA CLUTCH
CUBIERTA VOLANTE

PÁG. N° 3

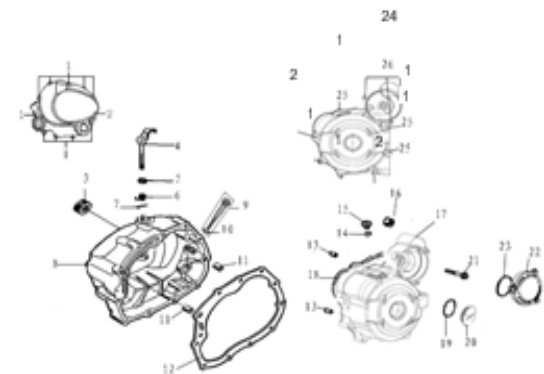

FIGURA N° 4: CLUTCH

PÁG. N°4

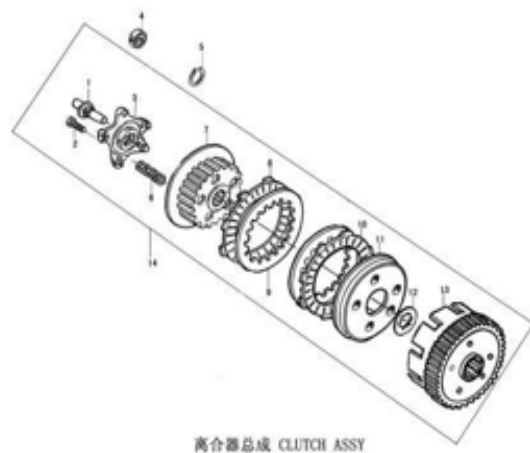

FIGURA N° 5: BOMBA ACEITE -
FILTRO CENTRIFUGO ACEITE

PÁG. N°5

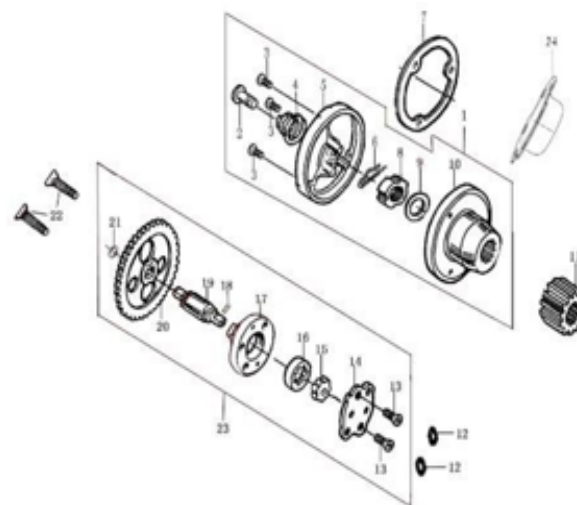

FIGURA N° 6: CARCASAS

PÁG. N°6 - 7

ÍNDICE DE GRÁFICOS

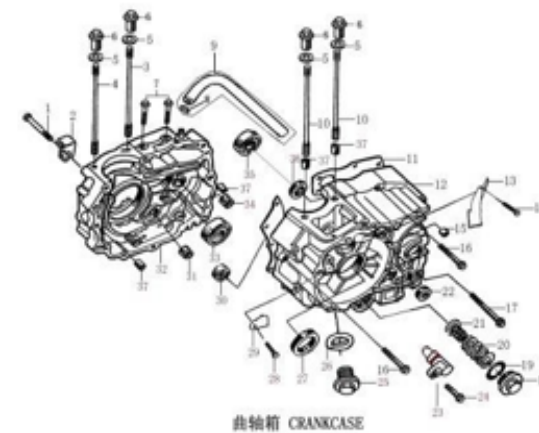

FIGURA N° 7: CIGÜEÑAL - PISTÓN

PÁG. N°8

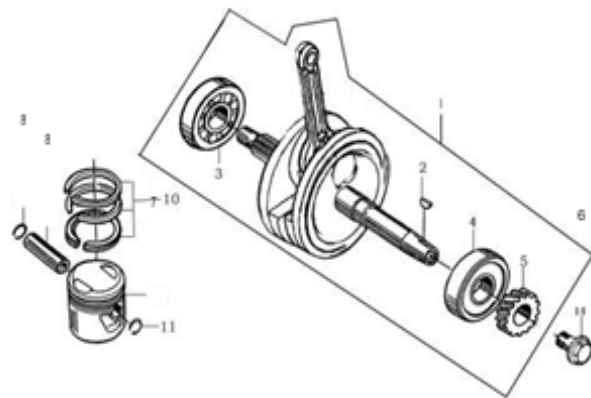

FIGURA N° 8: TRANSMISIÓN

PÁG. N°9
- 10

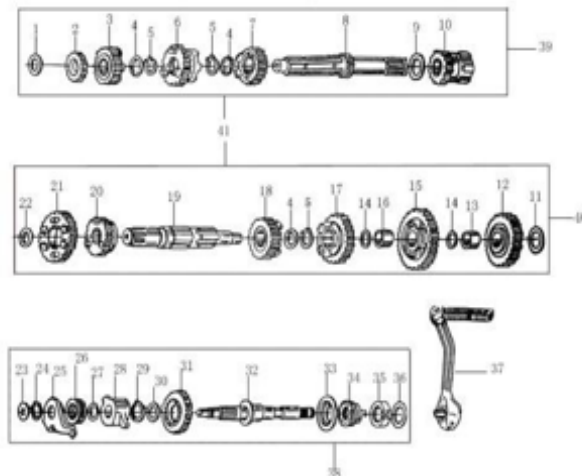

FIGURA N° 9: EJE CAMBIOS - EJE SELECTOR CAMBIOS

PÁG. N°.11

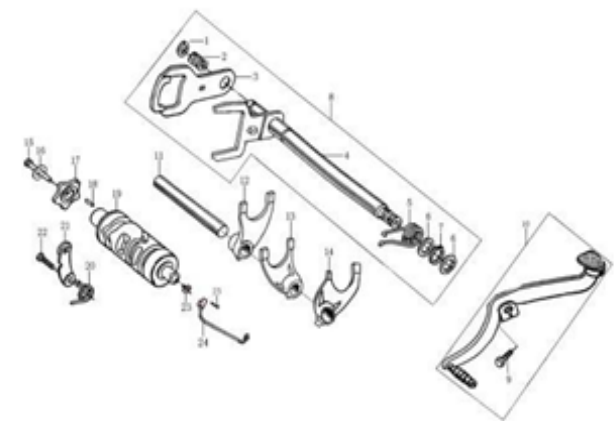

FIGURA N° 10: VOLANTE - PLATO BOBINAS

PÁG. N°.12

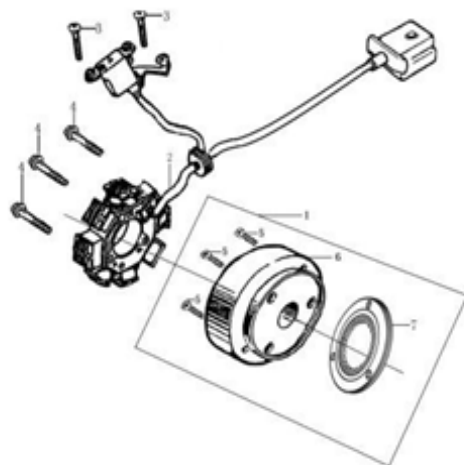

FIGURA N° 11: MOTOR DE ARRANQUE

PÁG. N°.13

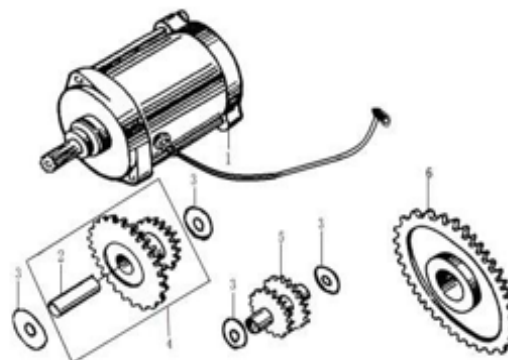

FIGURA N° 12: CAJA FILTRO AIRE - CARBURADOR

PÁG. N°.14

ÍNDICE DE GRÁFICOS

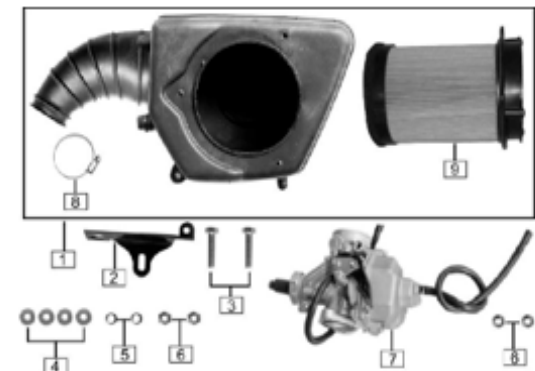

FIGURA N° 13: FAROLA - DIRECCIONALES DELANTERAS

PÁG. N°.
15



FIGURA N° 14: VELOCÍMETRO - SWICHE ENCENDIDO

PÁG. N°.
16

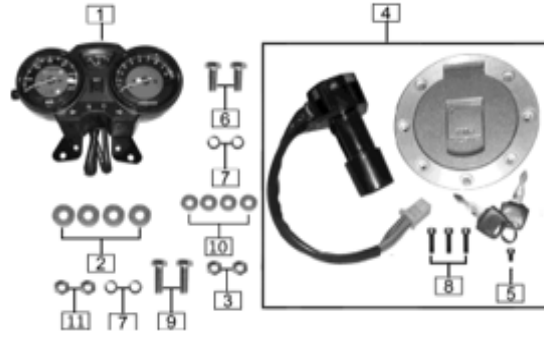

FIGURA N° 15: MANUBRIO COMANDOS ESPEJOS

PÁG. N°.
17

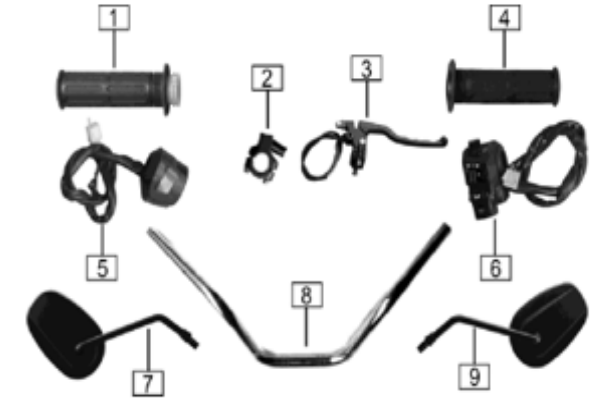

FIGURA N° 16: PEDAL CAMBIOS - PEDAL FRENO

PÁG. N°.
18

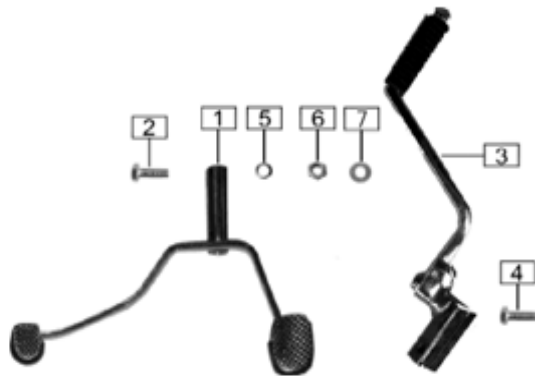

FIGURA N° 17: LLANTAS - RINES

PÁG. N°.
19



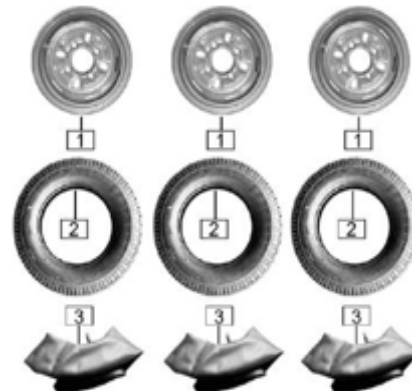

FIGURA N° 18: FRENO DELANTERO

PÁG. N°.
20

ÍNDICE DE GRÁFICOS

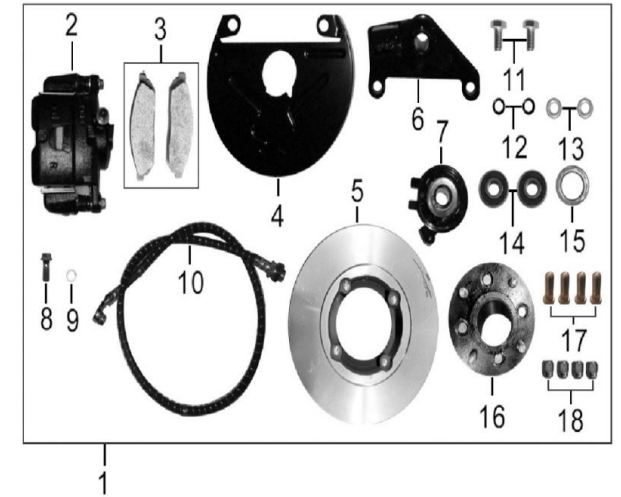
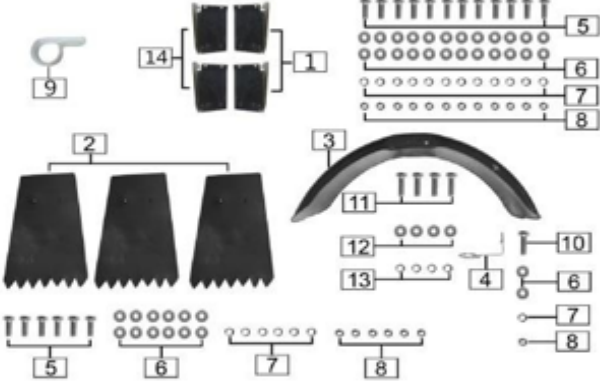
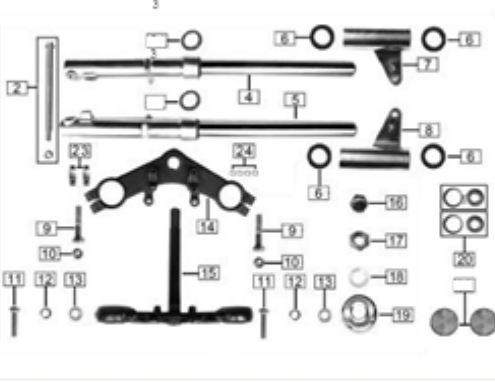
					
<p>FIGURA N° 19: GUARDABARRO DELANTERO GUARDABARRO TRASERO</p>	<p>PÁG. N°. 21</p>	<p>FIGURA N° 20: SUSPENSIÓN DELANTERA</p>	<p>PÁG. N°. 22</p>	<p>FIGURA N° 21: TANQUE GASOLINA</p>	<p>PÁG. N°. 23</p>
					
<p>FIGURA N° 22: COMPLEMENTOS CHASIS</p>	<p>PÁG. N°. 24</p>	<p>FIGURA N° 23: SILLÍN</p>	<p>PÁG. N°. 25</p>	<p>FIGURA N° 24: CAUCHO REPOSAPIE</p>	<p>PÁG. N°. 26</p>

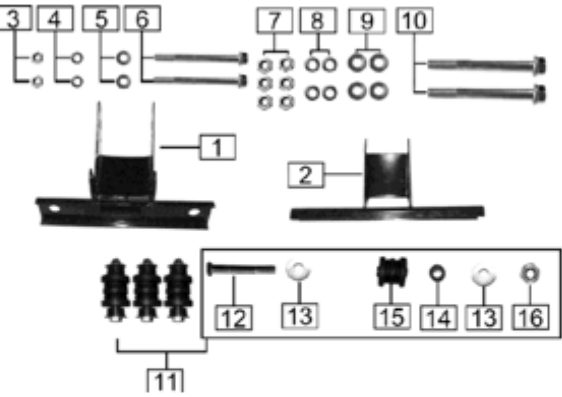
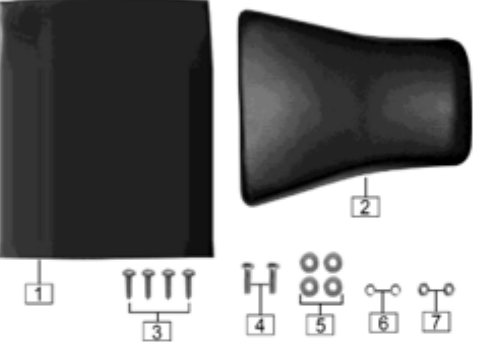
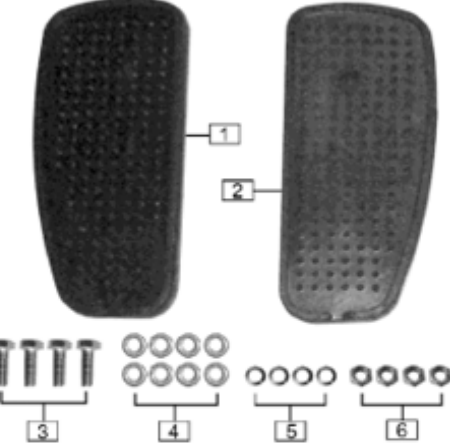
ÍNDICE DE GRÁFICOS

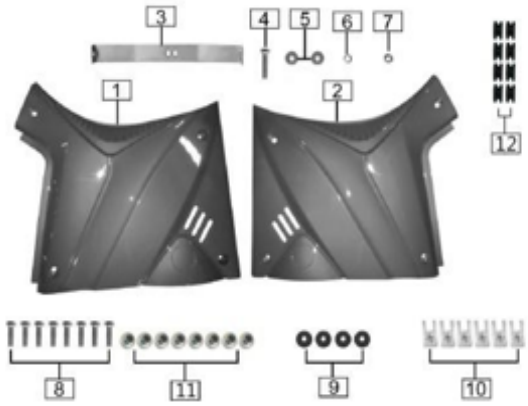
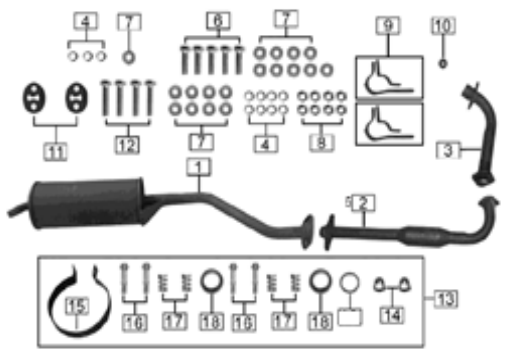
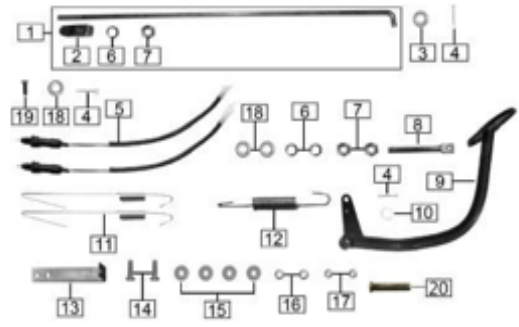
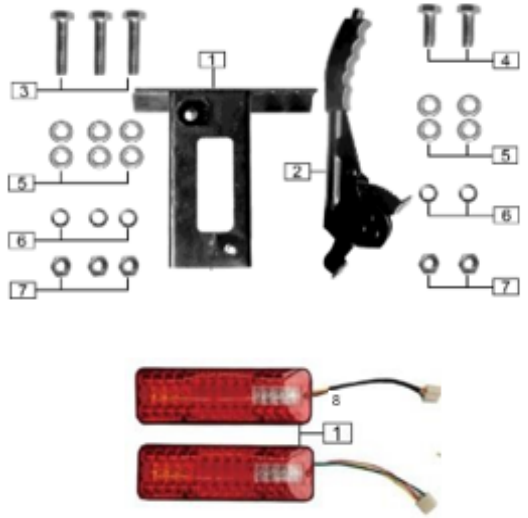
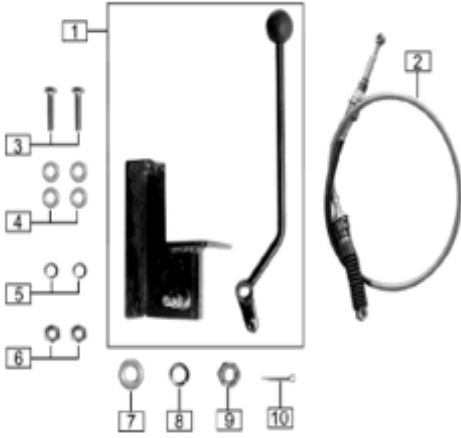
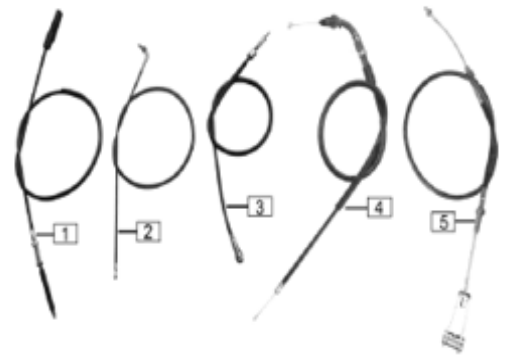
		
FIGURA N° 25: TAPAS LATERALES	FIGURA N° 26: SILENCIADOR	FIGURA N° 27: PEDAL FRENO - VARILLA FRENOTRASERO
PÁG. N° 27	PÁG. N° 28	PÁG. N° 29
		
FIGURA N° 28: PALANCA DE REVERSA - STOP	FIGURA N° 29: PALANCA CONTROL TRACCIÓN	FIGURA N° 30: CABLES
PÁG. N° 30	PÁG. N° 31	PÁG. N° 32

ÍNDICE DE GRÁFICOS



FIGURA N° 31: EQUIPO ELÉCTRICO

PÁG. N°.
33



FIGURA N° 32: VÁLVULA DE GASES

PÁG. N°.
34

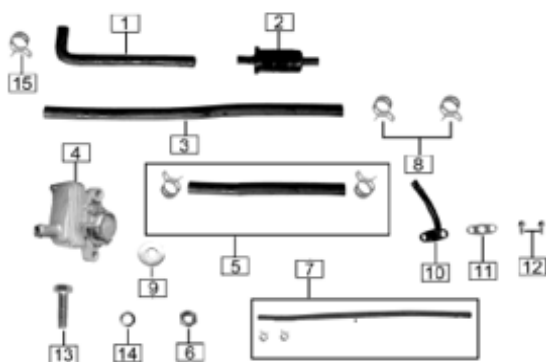

FIGURA N° 33: CHASIS

PÁG. N°.
35

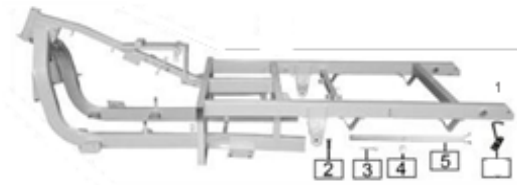

FIGURA N° 34: CARROCERÍA

PÁG. N°.
36

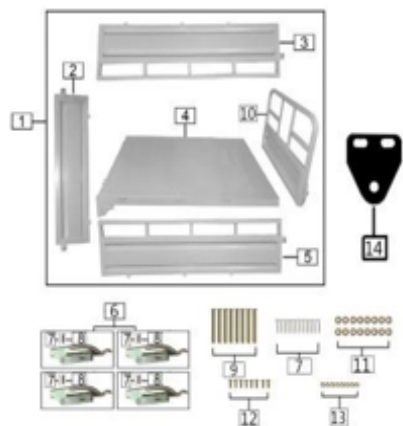

FIGURA N° 35: COMPLEMENTOS CARROCERÍA

PÁG. N°.
37

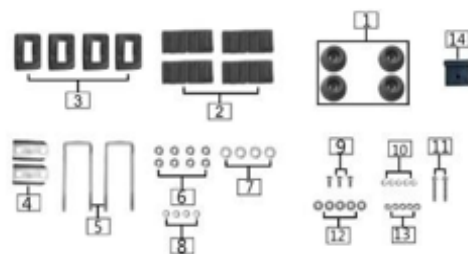

FIGURA N° 36: SUSPENSIÓN TRASERA

PÁG. N°.
38

ÍNDICE DE GRÁFICOS

			
FIGURA N° 37: CARDAN	PÁG. N°. 39	FIGURA N° 38: EJE TRANSMISIÓN	PÁG. N°. 40
			PÁG. N°. 41
FIGURA N° 40: BATERÍA	PÁG. N°. 39	FIGURA N° 41: COMPONENTES FRENO TRASERO	PÁG. N°. 40
FIGURA N° 42: CAJA REVERSA	PÁG. N°. 42	FIGURA N° 43: COMPONENTES FRENO TRASERO	PÁG. N°. 43 - 45
FIGURA N° 44: CAJA REVERSA	PÁG. N°. 46 - 47	FIGURA N° 45: COMPONENTES FRENO TRASERO	PÁG. N°. 46 - 47

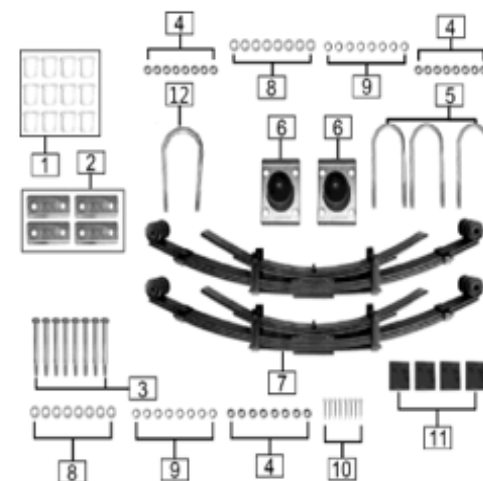
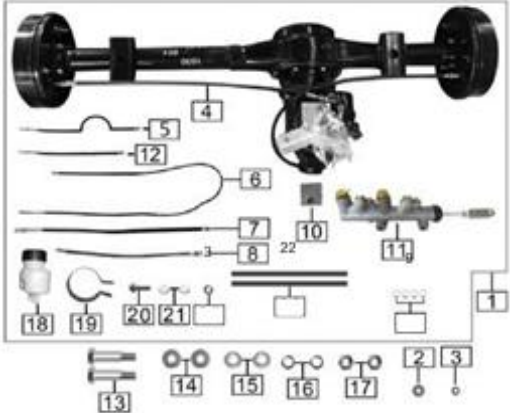
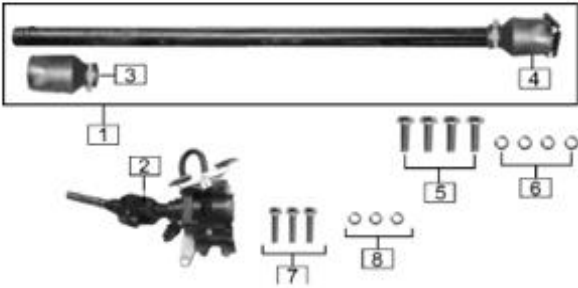
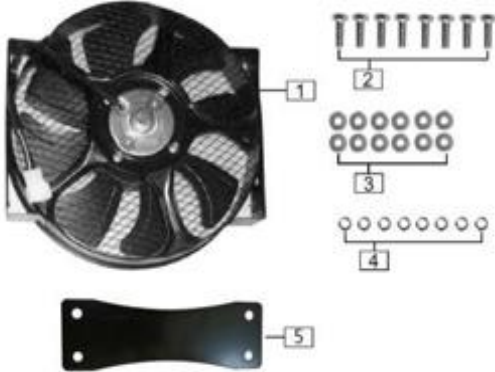
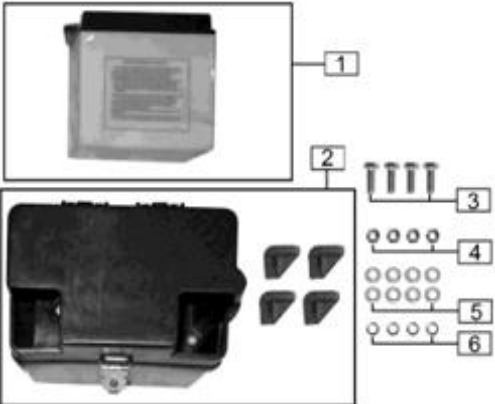
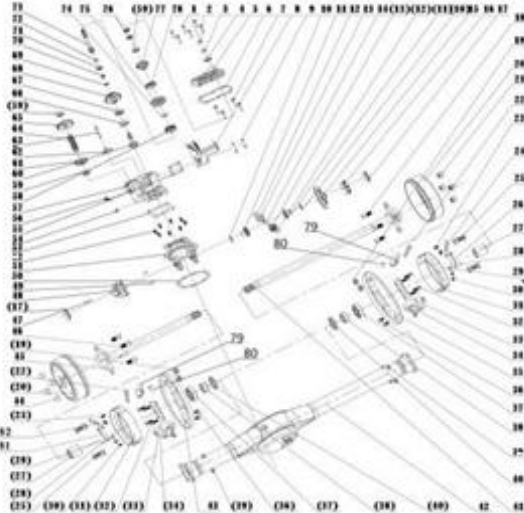
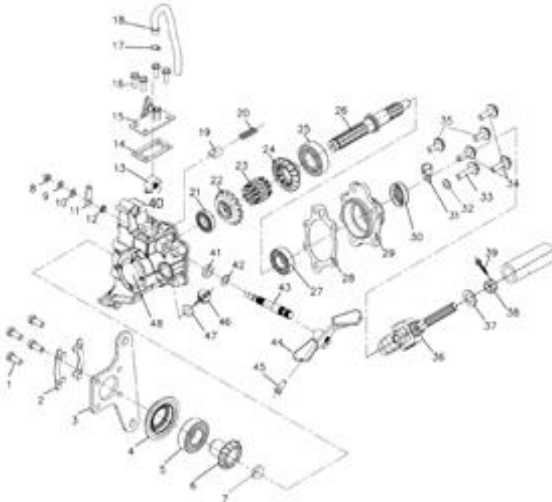
ÍNDICE DE GRÁFICOS



				
<p>FIGURA N° 43: CAJA DE HERRAMIENTAS - ESTUCHE HERRAMIENTAS</p>	<p>PÁG. N°. 48</p>	<p>FIGURA N° 44: CALCOMANÍAS</p>	<p>PÁG. N°. 49</p>	

FIGURA N°1: CULATA - CARBURADOR

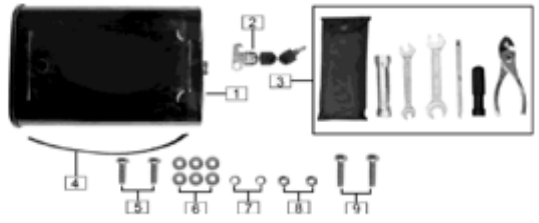
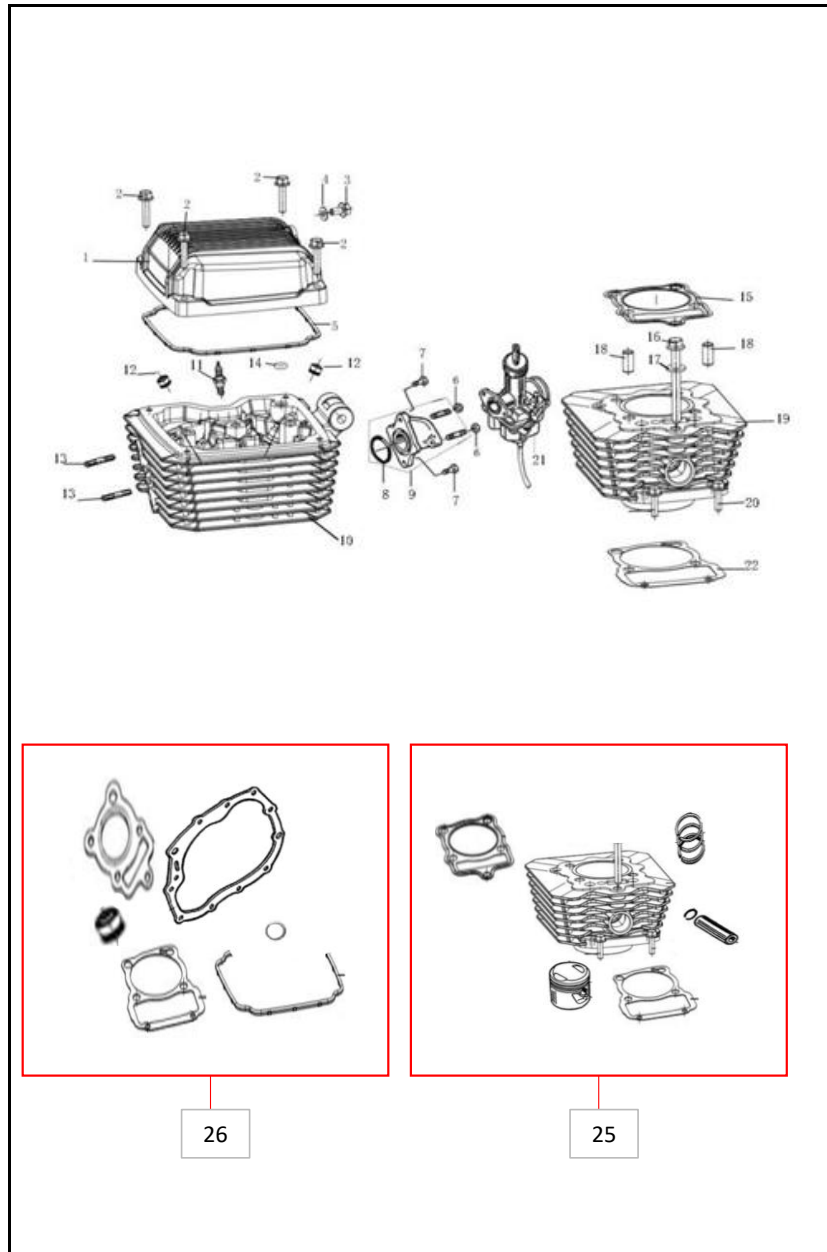

FIG. No.	PARTE N°	DESCRIPCIÓN	CANT.	SAP
1	100102855-0017	TAPA CULATA	1	11047797
2	100011269-0003	TORNILLO 6X28	4	11047744
3	100011261-0004	TORNILLO 6X12	1	11042029
4	100106538	ARANDELA 6.2X1.5X13	1	11042149
5	100104525	EMPAQUE TAPA CULATA	1	11041616
6	100011421-0003	TUERCA M6	2	11047745
7	100011174-0004	TORNILLO 6X20	2	11042212
8	100107759	ANILLO RETENEDOR 33.5X3	1	11047878
9	100711156	MÚLTIPLE ADMISIÓN	1	11047906
10	100140997-0002	CULATA	1	11047885
11	D8EA	BUJÍA NGK D8EA	1	21002156
12	100105336	RETEN VÁLVULA	2	11041594
13	100100440-0001	ESPARRAGO 10X40	2	11047777
14	100107796	ANILLO RETENEDOR 6.4X3	1	11047880
15	100208882	EMPAQUE CULATA	1	11041617
16	100100338-0005	TORNILLO 8X78	1	11047774
17	100106576	ARANDELA 8.5X2X18	1	11047874
18	100031687	PIN GUÍA 10X20	2	11047748
19	100140416-0002	CILINDRO (SOLO)	1	11047884
20	100011267-0003	TORNILLO 6X22	2	11047743
21	100300202	CARBURADOR	1	11047902
22	100108519	EMPAQUE CILINDRO	1	11041618
23	100208769	BAQUETA CARBURADOR(No ilustrado)	1	11047901
24	100201147	EMPAQUE MÚLTIPLE ADMISIÓN(No ilustrado)	1	11047888
25	21016855	KIT CILINDRO	1	21016855
26	21016934	KIT EMPAQUES	1	21016934

FIGURA N°2: EJE LEVAS - VÁLVULAS

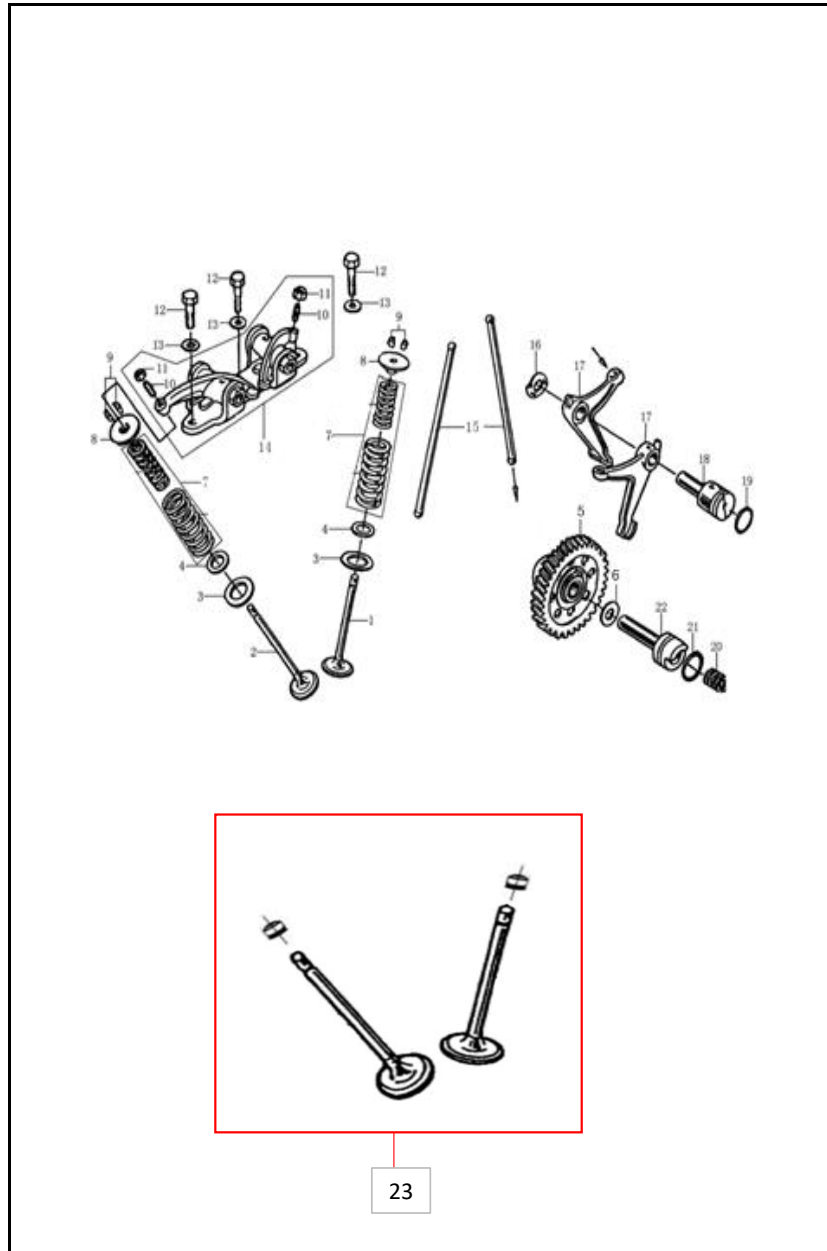

FIG. No.	PARTE N°	DESCRIPCIÓN	CANT.	SAP
1	100105269	VÁLVULA ADMISIÓN	1	11047844
2	100200646	VÁLVULA ESCAPE	1	11047887
3	100105315	ARANDELA INFERIOR RESORTE VÁLVULA	2	11047845
4	100105325	ARANDELA INFERIOR RESORTE VÁLVULA	2	11047846
5	100200256	PIÑÓN EJE LEVAS	1	11047886
6	100106407	ARANDELA 14.2X1X24	1	11047865
7	100065227	SET RESORTE VÁLVULA	2	11047761
8	100076574	ARANDELA SUPERIOR RESORTE VÁLVULA	2	11047762
9	100051841	CUÑA VÁLVULA	4	11041593
10	100105169	TORNILLO BALANCÍN	2	11047841
11	100105159	TUERCA BALANCÍN	2	11047840
12	100100483	TORNILLO 8X28	3	11047778
13	100106359	ARANDELA 8.5X2X18	3	11047861
14	100200427	SOPORTE BALANCÍN	1	11040622
15	100105077	BOTADOR	2	11040623
16	100106645	ARANDELA 12.3X0.2X20.9	1	11047875
17	100105172	BALANCÍN	2	11047842
18	100105175	EJE BALANCÍN	1	11047843
19	100107691	ANILLO RETENEDOR 18X2.5	1	11047876
20	100104988	RESORTE EJE LEVAS	1	11047839
21	100107704	ANILLO RETENEDOR 20X2.5	1	11047877
22	100052427	EJE LEVAS	1	11047755
23	21016971	KIT VALVULAS	1	21016971

FIGURA N°3: CUBIERTA CLUTCH - CUBIERTA VOLANTE

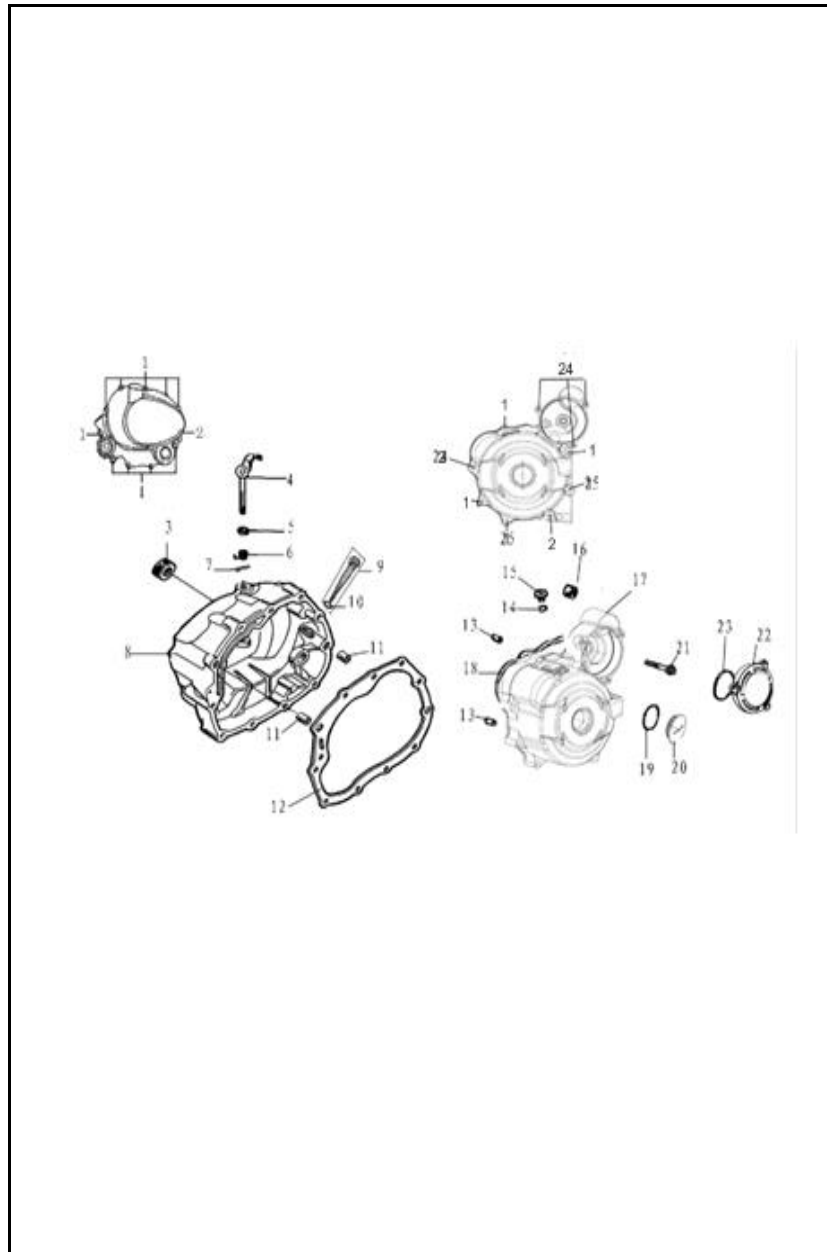

FIG. No.	PARTE N°	DESCRIPCIÓN	CANT.	SAP
1	100011538-0003	TORNILLO 6X40	15	11042220
2	100011540-0007	TORNILLO 6X50	3	11047747
3	100104735	RETEN 16-28-7	1	11041609
4	100203152-0005	EJE INTERNO CUBIERTA CLUTCH	1	11047895
5	100104756	RETEN 12-22-5	1	11041610
6	100103443	RESORTE EJE INTERNO CUBIERTA CLUTCH	1	11042095
7	100100636-0001	PIN PASADOR	1	11042232
8	100202035-0219	CUBIERTA CLUTCH	1	11047891
9	100303194	TAPÓN NIVEL ACEITE	1	11047905
10	100031573	ANILLO RETENEDOR 18X3	1	11042036
11	100100868	PIN GUÍA 8X14	2	11042071
12	100104571	EMPAQUE CUBIERTA CLUTCH	1	11041619
13	100010557	PIN GUÍA 10X14	2	11047732
14	100010074	ANILLO RETENEDOR 13.2X2.65	1	11047728
15	100103059-0074	TAPÓN CUBIERTA VOLANTE	1	11047802
16	100101202	RODAMIENTO AGUJAS	1	11047790
17	100204805-1793	CUBIERTA VOLANTE	1	11047899
18	100104546	EMPAQUE CUBIERTA VOLANTE	1	11041620
19	100107733	ANILLO RETENEDOR 27.4X2.65	1	11042152
20	100103064-0032	TAPÓN CUBIERTA VOLANTE	1	11047803
21	100011534-0002	TORNILLO 6X25	1	11047746
22	100100005-0049	TAPA CUBIERTA VOLANTE	1	11047763
23	100107808	EMPAQUE TAPA CUBIERTA VOLANTE	1	11047881
24	100055588-0006	TORNILLO 6X20	3	11042225

FIGURA N° 5: BOMBA ACEITE - FILTRO CENTRIFUGO ACEITE

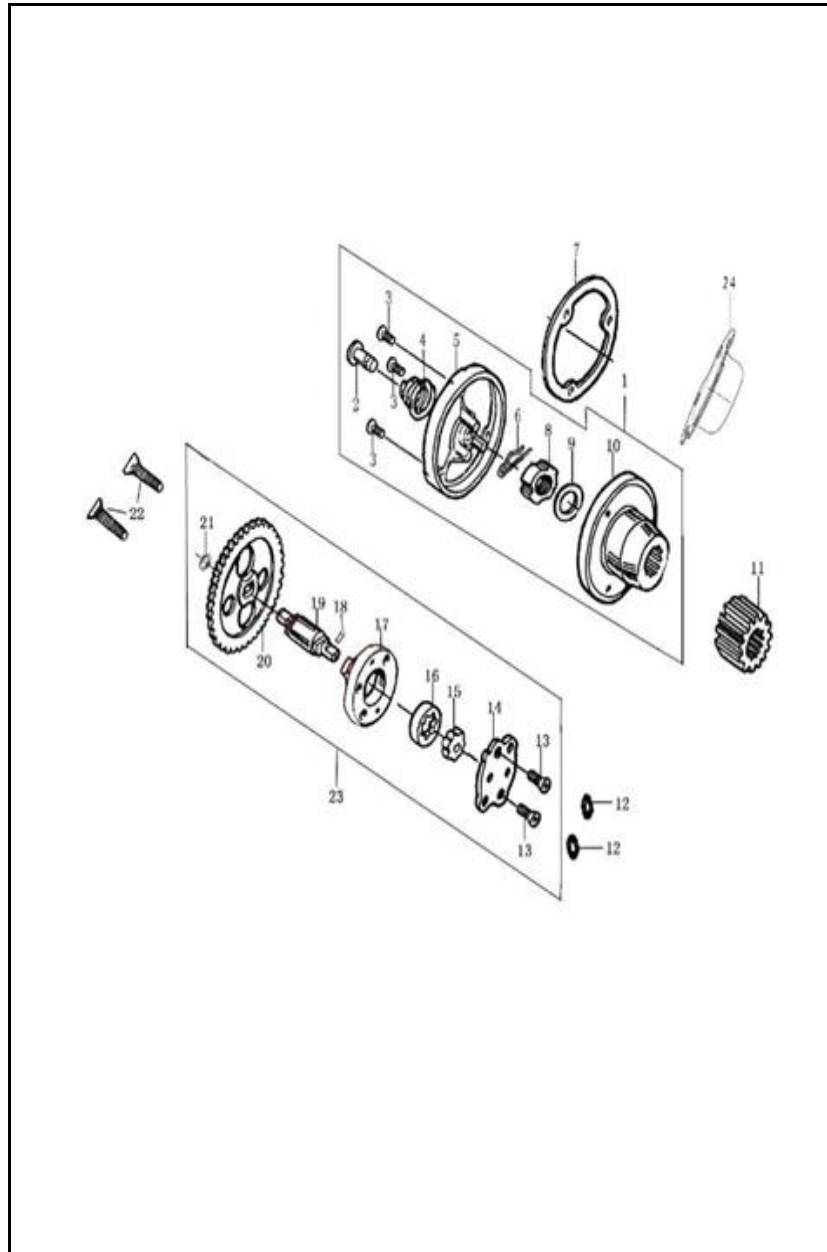

FIG. No.	PARTE N°	DESCRIPCIÓN	CANT.	SAP
1	100200004	FILTRO CENTRIFUGO ACEITE	1	11041626
2	100104843	CONDUCTO FILTRO CENTRIFUGO ACEITE	1	11047834
3	100010969-0001	TORNILLO 5X12	3	11047738
4	100104844	RESORTE FILTRO CENTRIFUGO ACEITE	1	11042126
5	14207-1006-0100	CUBIERTA FILTRO CENTRIFUGO ACEITE	1	11047908
6	100104850	PIN DE SEGURIDAD	1	11042128
7	100208725	EMPAQUE FILTRO CENTRIFUGO ACEITE	1	11042200
8	100100523	TUERCA	1	11047780
9	100103345	ARANDELA 16.5X2X27	1	11047807
10	14205-1006-0300	CAMPANA FILTRO CENTRIFUGO ACEITE	1	11047907
11	100103486	PIÑÓN PRIMARIO	1	11047808
12	100107842	ANILLO RETENEDOR 9.4X2.4	2	11047882
13	100010946-0003	TORNILLO 4X10	2	11047737
14	100100166	ACOPLE CUERPO BOMBA ACEITE	1	11047766
15	100100195	ROTOR INTERNO BOMBA ACEITE	1	11047769
16	100100206	ROTOR EXTERNO BOMBA ACEITE	1	11047770
17	100100187	CUERPO BOMBA ACEITE	1	11047768
18	100032890	PIN 2.5X10	1	11042037
19	100100156	EJE BOMBA ACEITE	1	11047765
20	100100176	PINON BOMBA ACEITE	1	11047767
21	100011111	PIN DE SEGURIDAD 6 MM.	1	11042035
22	100123472-0002	TORNILLO 6X32	2	11047883
23	100100071	BOMBA ACEITE	1	11047764
24	100104851	ACOPLE FILTRO CENTRIFUGO ACEITE	1	11047835

FIGURA N° 6: CARCASAS (1/2)

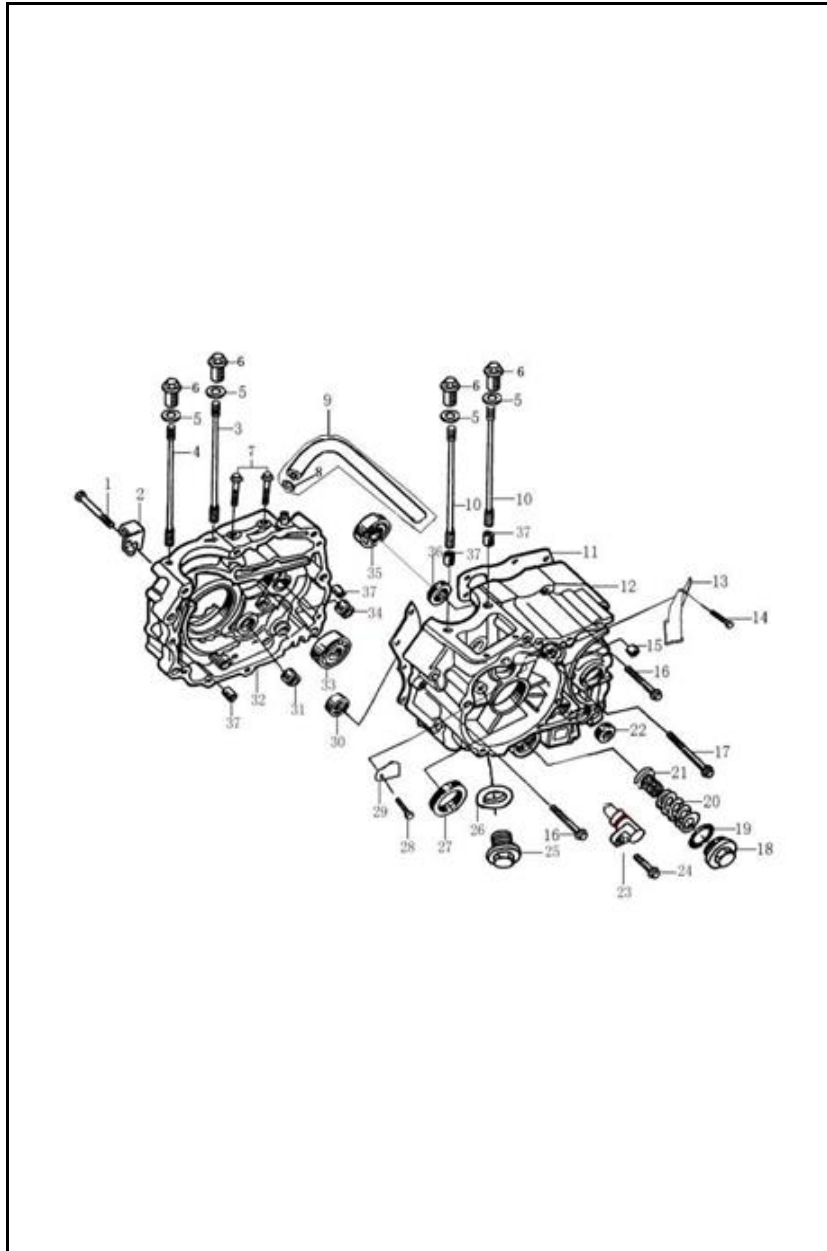

FIG. No.	PARTE N°	DESCRIPCIÓN	CANT.	SAP
1	100031958-0007	TORNILLO 6X55	1	11047749
2	100106281-0006	GUIA CABLE CLUTCH	1	11047859
3	100100263	ESPARRAGO CARCASA A	1	11047771
4	100100264	ESPARRAGO CARCASA A	1	11047772
5	100106609	ARANDELA 12.5X2X22	4	11042151
6	100100532-0002	TORNILLO TAPON 8X32	4	11047781
7	100011269-0003	TORNILLO 6X28	2	11047744
8	100105484	ABRAZADERA	1	11047851
9	100056114	MANGUERA DE DESFOGUE	1	11047758
10	100100316	ESPARRAGO CARCASA B	2	11047773
11	100104589	EMPAQUE CENTRO MOTOR	1	11041622
12	100102960-0083	CARCASA IZQUIERDA	1	11047800
13	100102901	PLATINA GUIA	1	11047799
14	100055591-0006	TORNILLO 6X12	1	11042227
15	100101202	RODAMIENTO AGUJAS	1	11047790
16	100011540-0007	TORNILLO 6X50	9	11047747
17	100031961-0007	TORNILLO 6X95	1	11047750
18	100102871-0002	TAPON CEDAZO FILTRO ACEITE	1	11047798
19	100107766	ANILLO RETENEDOR 35X3	1	11047879
20	100104866	RESORTE TAPON CEDAZO FILTRO ACEITE	1	11047836
21	100104943	CEDAZO FILTRO ACEITE	1	11047837
22	100104652	RETEN 14-28-7	1	11041623
23	100103008	INYECTOR	1	11047801
24	100011534-0002	TORNILLO 6X25	1	11047746
25	100100331-0006	TORNILLO TAPON DERENAJE ACEITE	1	

FIGURA N° 7: CIGÜEÑAL - PISTÓN

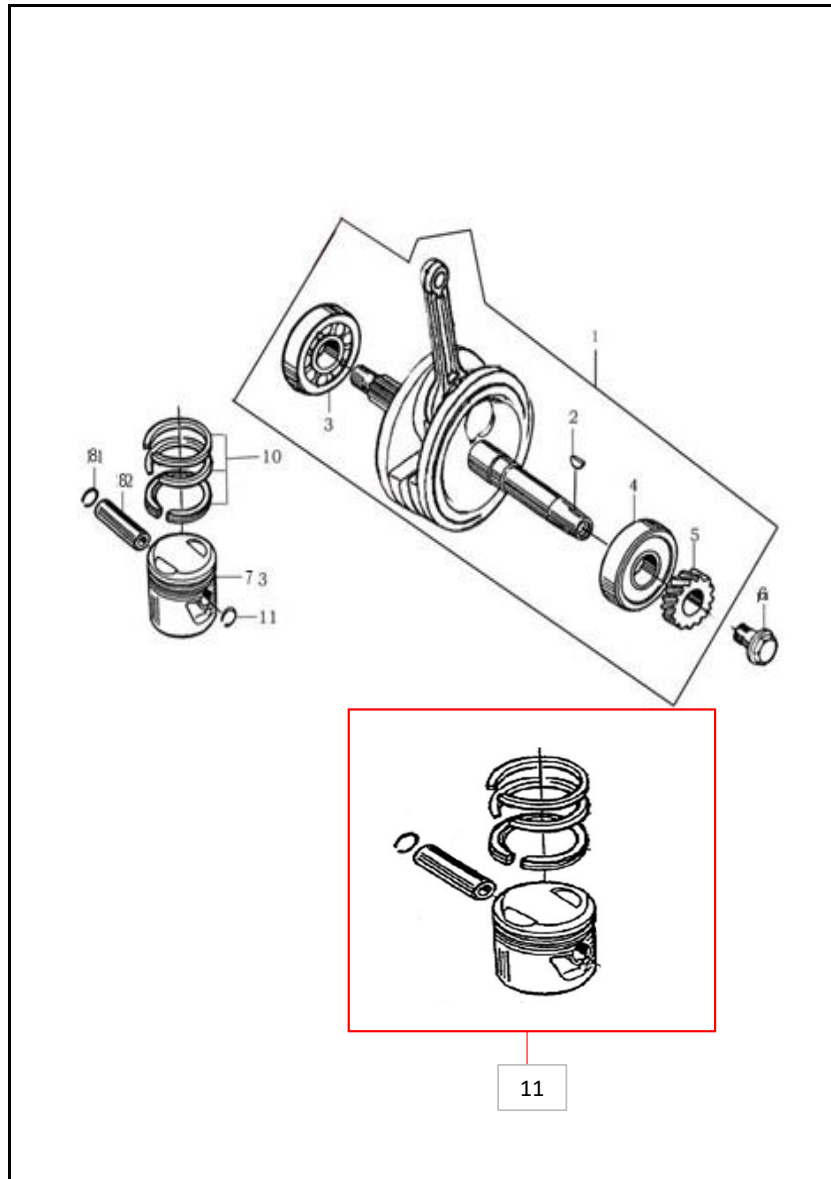

FIG. No.	PARTE N°	DESCRIPCIÓN	CANT.	SAP
1	100303110	CIGÜEÑAL	1	11047904
2	100100643	CUÑA CIGÜEÑAL	1	11042070
3	100101055	RODAMIENTO BOLAS 63-28-P5	1	11047786
4	100101197	RODAMIENTO BOLAS 63-28-RS-P5	1	11047789
5	100101958	PIÑÓN CIGÜEÑAL	1	11047795
6	100050578	TORNILLO 10X36	1	11047753
7	100101460-0002	PISTÓN STD (SOLO)	1	11047792
8	100101534	PASADOR PISTÓN	1	11047793
9	100100582	PIN PASADOR PISTÓN	2	11047782
10	100101654	ANILLOS STD	1	11047794
11	21016963	KIT PISTON		

FIGURA N°8: TRANSMISIÓN (1/2)

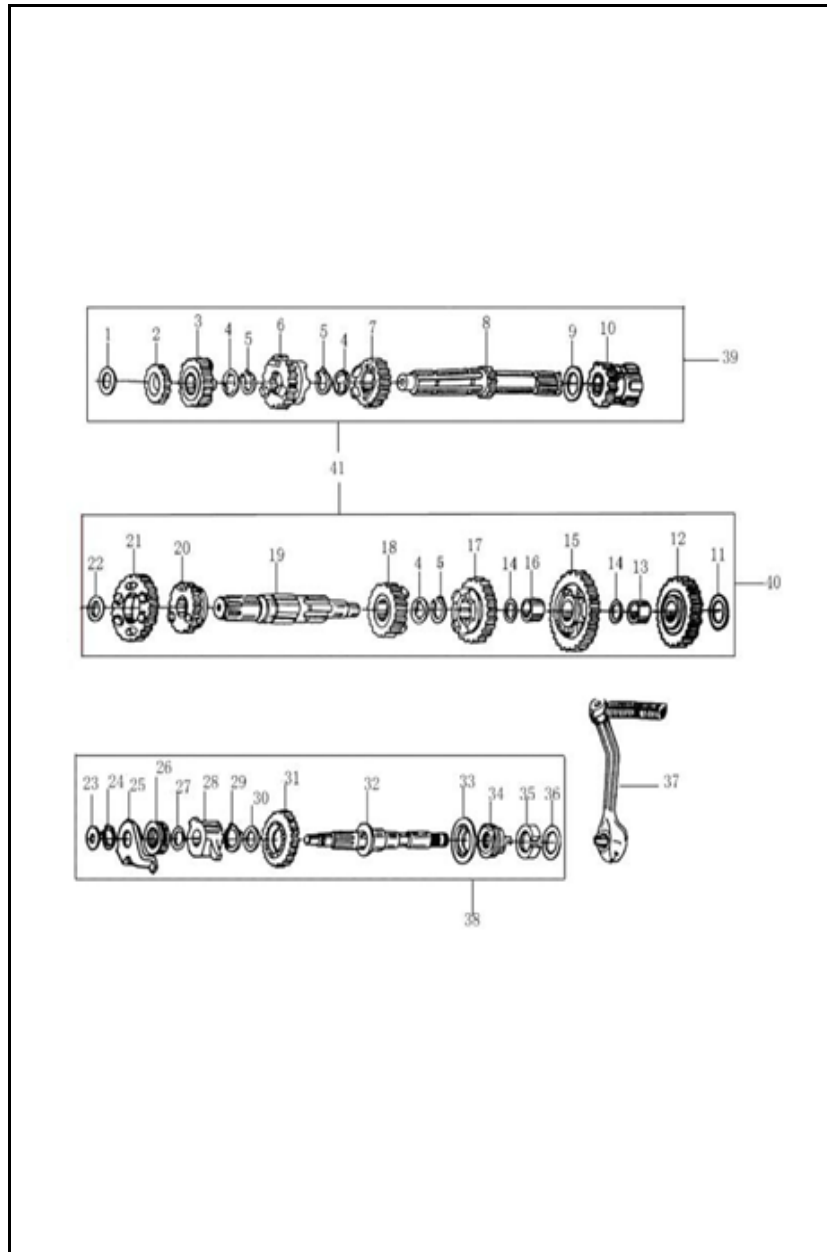

FIG. No.	PARTE N°	DESCRIPCIÓN	CANT.	SAP
1	100106510	ARANDELA 15.2X1X25	1	11047870
2	100103633	PIÑÓN 2DA. EJE CLUTCH	1	11047811
3	100103636	PIÑÓN 5TA. EJE CLUTCH	1	11047814
4	100103647	ARANDELA 17.3X1.6X26	3	11047815
5	100100596	PIN DE SEGURIDAD	3	11047783
6	100103635	PIÑÓN 4TA. EJE CLUTCH	1	11047813
7	100103634	PIÑÓN 3RA. EJE CLUTCH	1	11047812
8	100052667	EJE CLUTCH (SOLO)	1	11047756
9	100106525	ARANDELA 20.2X0.5X27	1	11047873
10	100053061	PIÑÓN EJE CLUTCH	1	11047757
11	100106511	ARANDELA 15.2X1X30	1	11047871
12	100103778	PIÑÓN EJE SALIDA	1	11047822
13	100103565	BUJE PIÑÓN EJE SALIDA	1	11047810
14	100106434	ARANDELA 16.5X0.5X24	2	11047868
15	100103743	PIÑÓN 1RA. EJE SALIDA	1	11047817
16	100103564	BUJE PIÑÓN 1RA. EJE SALIDA	1	11047809
17	100103748	PIÑÓN 3RA. EJE SALIDA	1	11047821
18	100103746	PIÑÓN 4TA. EJE SALIDA	1	11047819
19	100103693	EJE SALIDA (SOLO)	1	11047816
20	100103747	PIÑÓN 5TA. EJE SALIDA	1	11047820
21	100103744	PIÑÓN 2DA. EJE SALIDA	1	11047818
22	100106460	ARANDELA 20X1X27	1	11047869
23	100106396	ARANDELA 12.1X1X18	1	11047863
24	100011098	PIN DE SEGURIDAD 16 MM.	1	11042033
25	100105793	LEVA EJE CRANK	1	11047858

FIGURA N°8: TRANSMISIÓN (2/2)

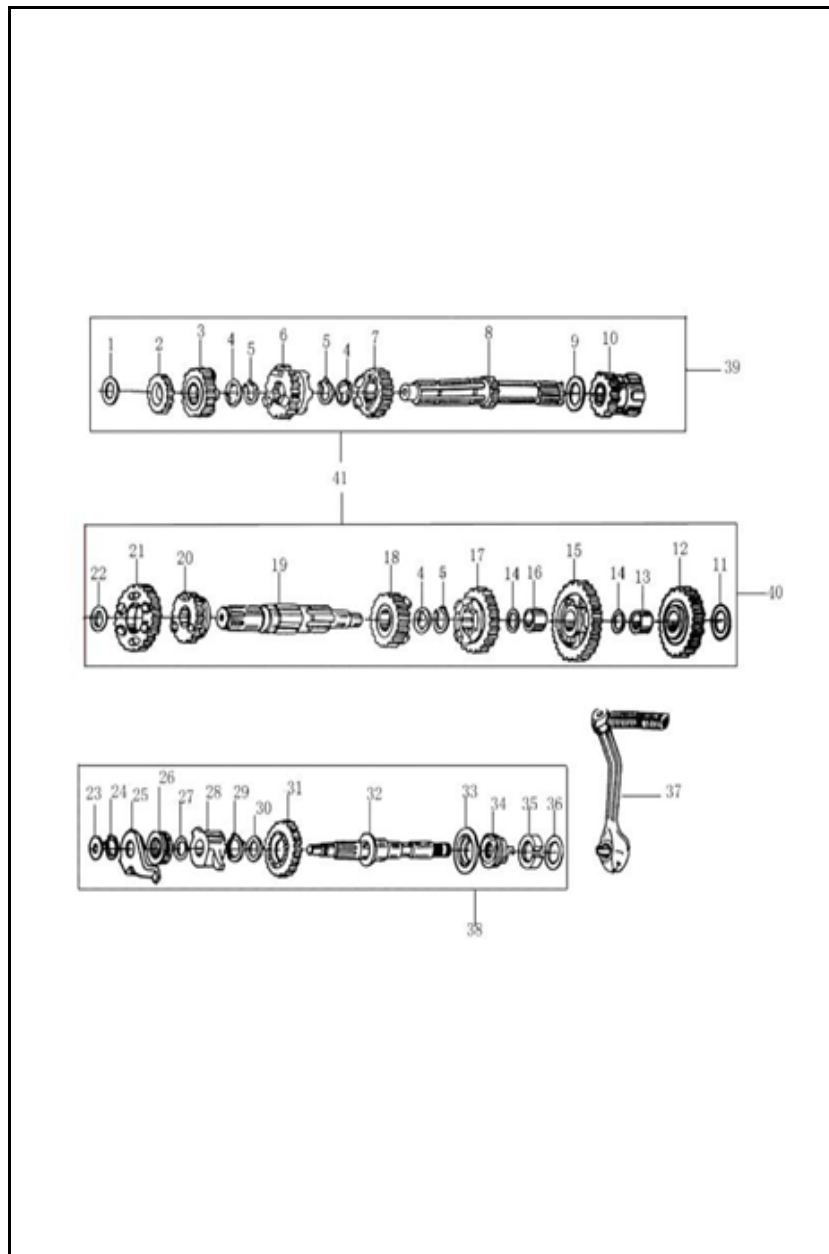

FIG. No.	PARTE N°	DESCRIPCIÓN	CANT.	SAP
26	100105788	RESORTE EJE CRANK	1	11047857
27	100106425	ARANDELA 16.1X1X24	1	11047866
28	100105783	ACOPLE RESORTE EJE CRANK	1	11047856
29	100100598	PIN DE SEGURIDAD	1	11047784
30	100106522	ARANDELA 20X0.5X27	1	11047872
31	100102487	PIÑÓN EJE CRANK	1	11047796
32	100105753-0001	EJE CRANK (SOLO)	1	11047854
33	100105740	ASIENTO RESORTE EJE CRANK	1	11047852
34	100105746	RESORTE EJE CRANK	1	11047853
35	100105763	BUJE	1	11047855
36	100106426	ARANDELA 16.1X1X30	1	11047867
37	21200-1008-0009	PEDAL CRANK	1	11017225
38	100201864	EJE CRANK COMPLETO	1	11047890
39	100061576	EJE CLUTCH COMPLETO	1	11047760
40	100203572	EJE SALIDA COMPLETO	1	11047896

FIGURA N° 9: EJE CAMBIOS - EJE SELECTOR CAMBIOS

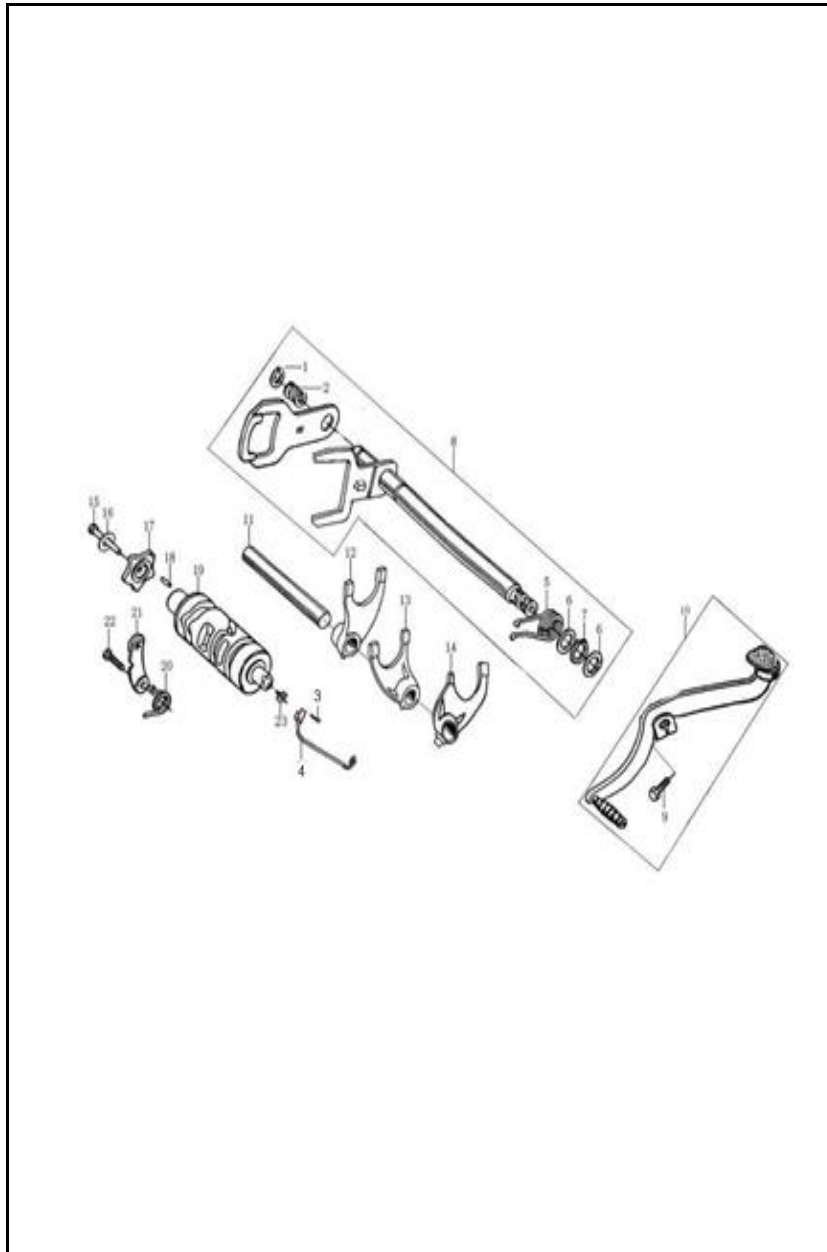

FIG. No.	PARTE N°	DESCRIPCIÓN	CANT.	SAP
1	100011095	PIN DE SEGURIDAD	1	11047740
2	100103978	RESORTE EJE CAMBIOS	1	11047828
3	100010979-0003	TORNILLO 6X20	1	11047739
4	100104492-0035	SWICHE NEUTRA	1	11047832
5	100203926	RESORTE EJE CAMBIOS	1	11047898
6	100106402	ARANDELA 14X0.5X20	2	11047864
7	100011096	PIN DE SEGURIDAD	1	11042032
8	100106303-0002	EJE CAMBIOS	1	11047860
9	100011174-0006	TORNILLO 6X20	1	11047742
10	24400-1008-0016	PEDAL CAMBIOS	1	11047931
11	100103914	EJE HORQUILLA CAMBIOS	1	11047826
12	100103895	HORQUILLA CAMBIOS	1	11047823
13	100103904	HORQUILLA CAMBIOS	1	11047825
14	100103899	HORQUILLA CAMBIOS	1	11047824
15	100100420-0002	TORNILLO EJE SELECTOR CAMBIOS	1	11047776
16	100010886-0005	ARANDELA 6 MM.	1	11047736
17	100103944	ESTRELLA EJE SELECTOR CAMBIOS	1	11047827
18	100032886	PIN 4X10	1	11047751
19	100203832	EJE SELECTOR CAMBIOS	1	11047897
20	100103981	RESORTE LEVA EJE SELECTOR CAMBIOS	1	11047829
21	100059045	LEVA EJE SELECTOR CAMBIOS	1	11047759
22	100100387-0002	TORNILLO LEVA EJE SELECTOR CAMBIOS	1	11047775
23	100104487	UNIÓN SWICHE NEUTRA	1	11047831

FIGURA N° 10: VOLANTE - PLATO BOBINAS

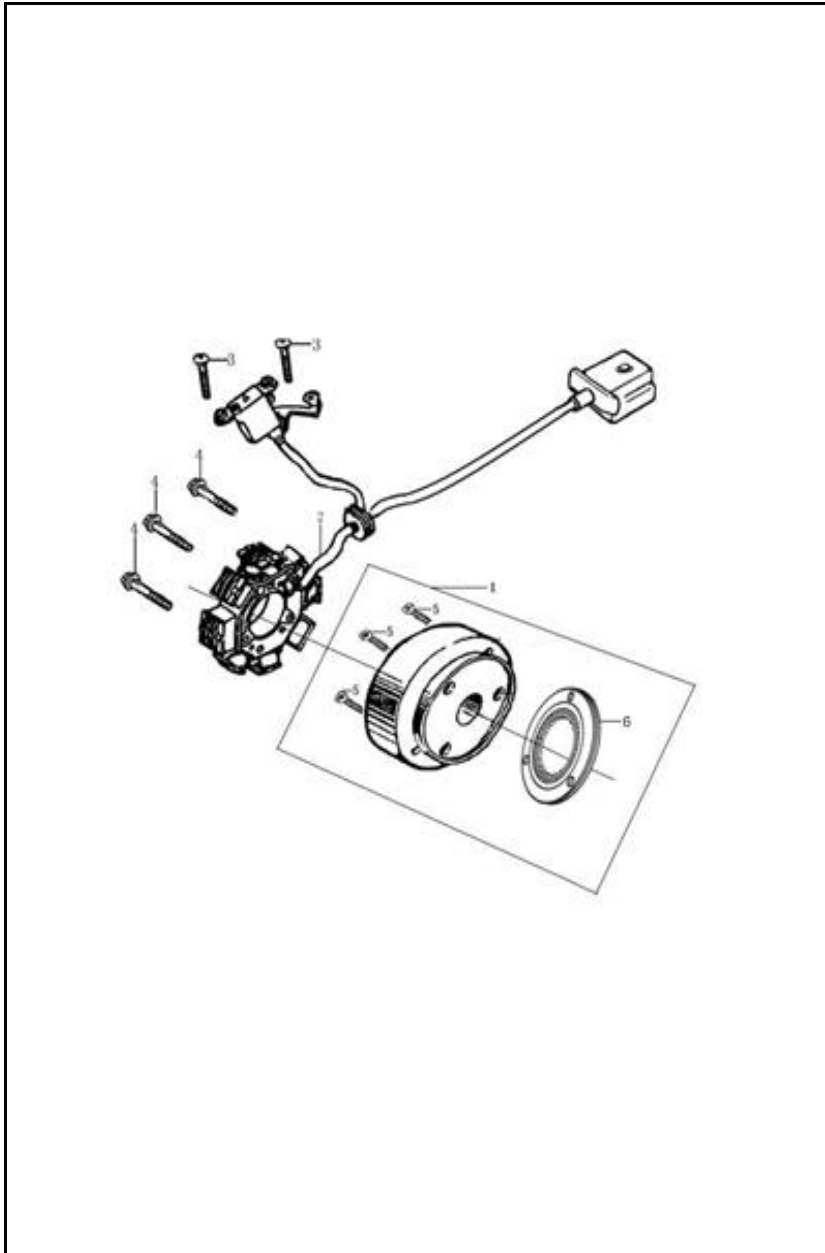

FIG. No.	PARTE N°	DESCRIPCIÓN	CANT.	SAP
1	100051148-0007	VOLANTE CON CLUTCH DE UNA VÍA	1	11047754
2	100205053-0127	PLATO BOBINAS	1	22000846
3	100011169-0004	TORNILLO 5X16	2	11047741
4	100011170-0003	TORNILLO 5X25	3	11042210
5	100100499-0001	TORNILLO 8X18	3	11047779
6	100103204	CLUTCH DE UNA VÍA	1	11047804

FIGURA N° 11: MOTOR DE ARRANQUE

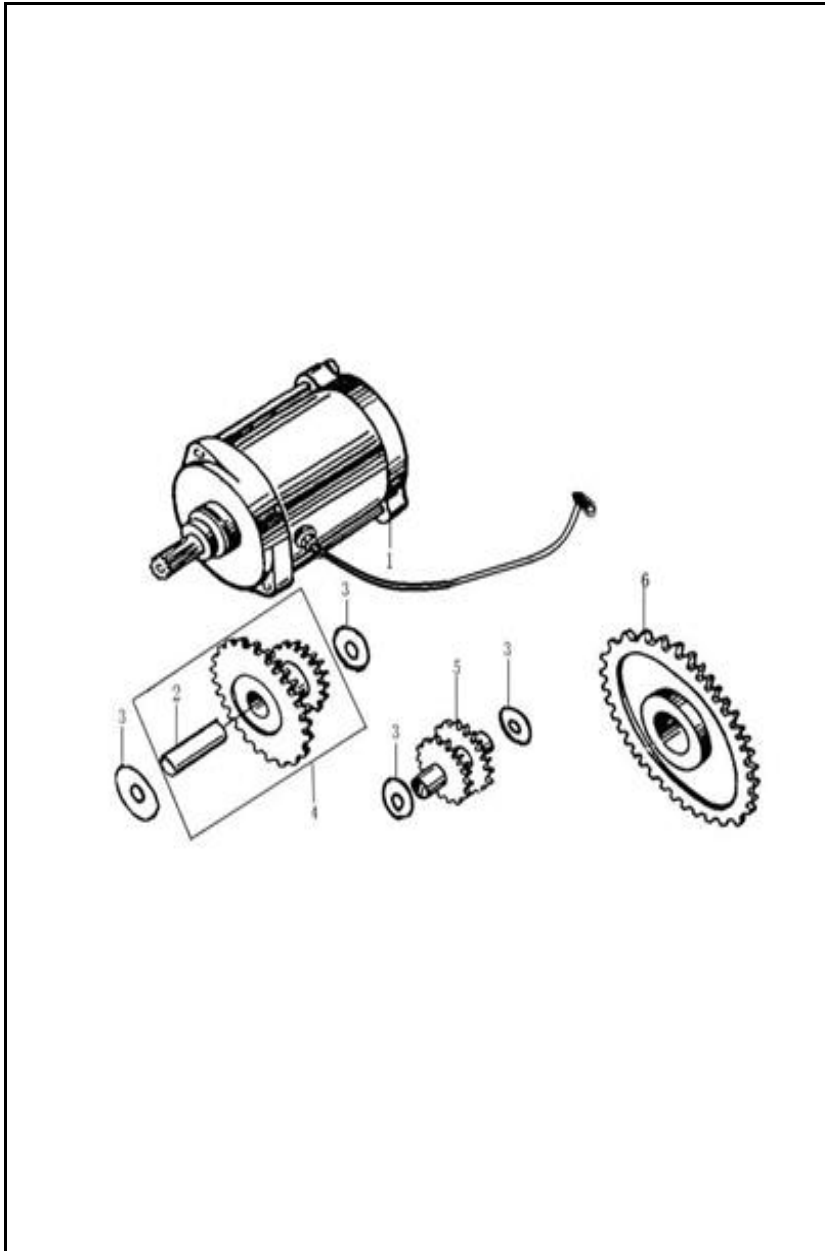

FIG. No.	PARTE N°	DESCRIPCIÓN	CANT.	SAP
1	100104252-0013	MOTOR DE ARRANQUE	1	11047830
2	100202640	EJE PIÑÓN REDUCCIÓN ARRANQUE	1	11047892
3	100106391	ARANDELA 10.5X0.5X18	4	11047862
4	100202661	PIÑÓN REDUCCIÓN ARRANQUE	1	11047893
5	100103220	PIÑÓN REDUCCIÓN ARRANQUE	1	11047805
6	100103267	PIÑÓN ARRANQUE	1	11047806

FIGURA N° 12: CAJA FILTRO AIRE - CARBURADOR

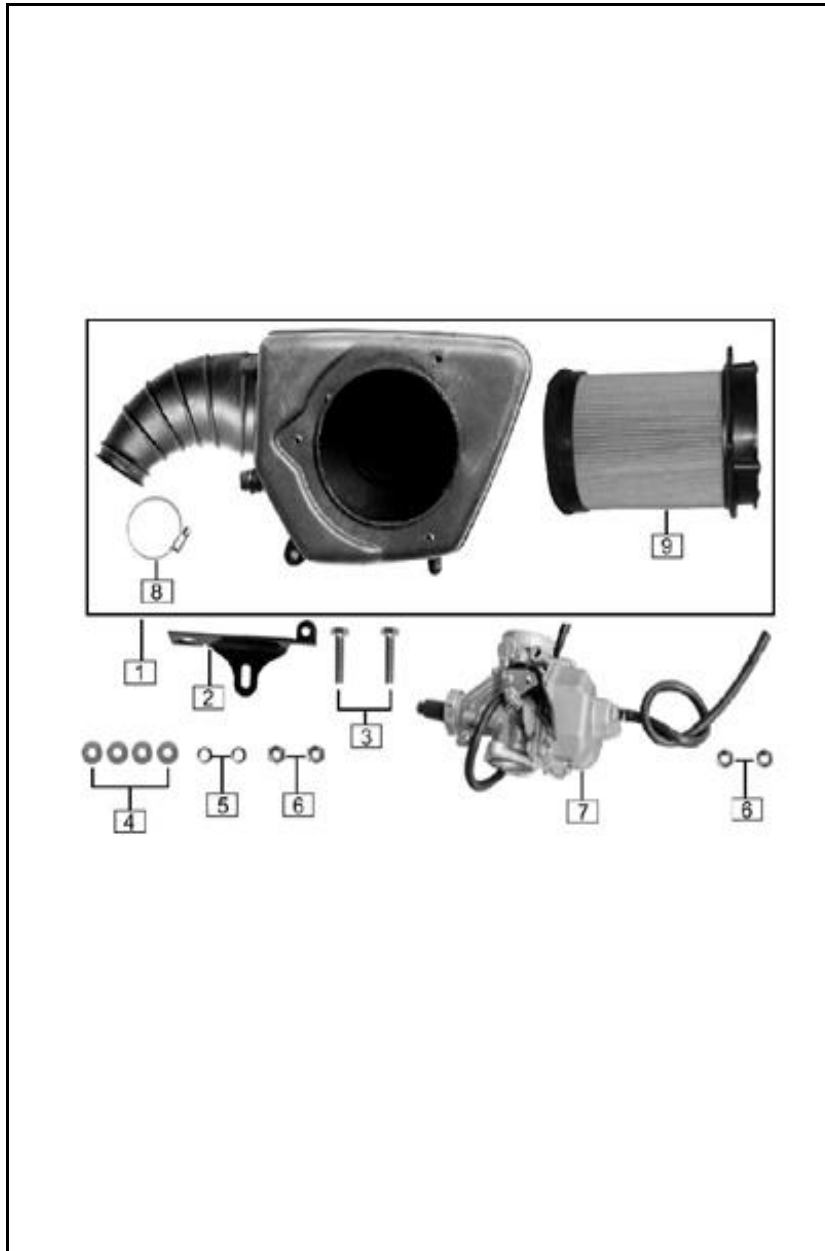

FIG. No.	PARTE N°	DESCRIPCIÓN	CANT.	SAP
1	16100-L3L6-0000	CAJA FILTRO AIRE	1	22000172
2	31334-0000-0100	SOPORTE CAJA FILTRO AIRE	1	22000168
3	B057830006002571C	TORNILLO 6X25	2	11048190
4	B000960206000021C	ARANDELA 6 MM.	4	11052679
5	B0009300060000U1C	ARANDELA DE PRESIÓN 6 MM.	2	11048155
6	B061700006000061C	TUERCA M6	4	11048211
7	17100-L1A8-0100	CARBURADOR	1	22000128
8	1613F-L3L6-0000	ABRAZADERA	1	11047909
9	16101-L3L6-0000	FILTRO AIRE	1	11041595

FIGURA N° 14: VELOCÍMETRO - SWICHE ENCENDIDO

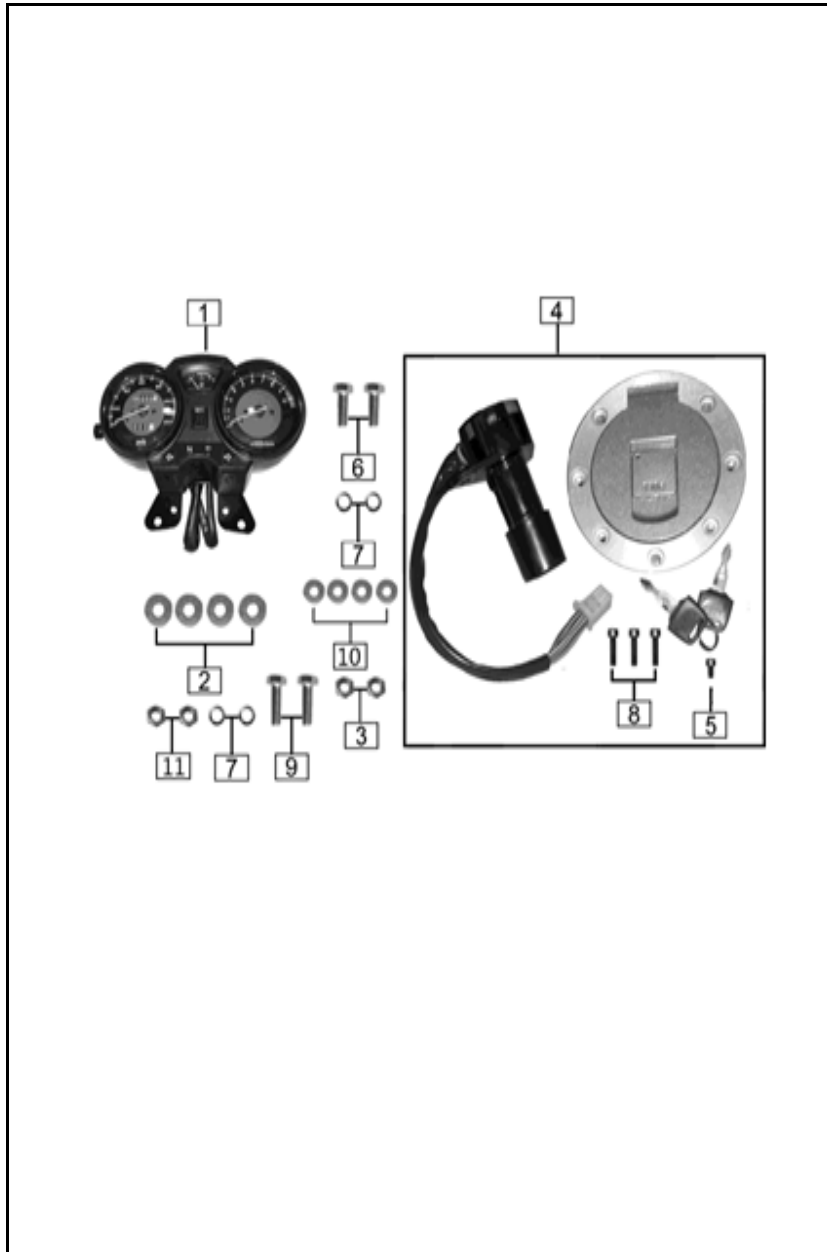

FIG. No.	PARTE N°	DESCRIPCIÓN	CANT.	SAP
1	87100-M1B5-0500	VELOCÍMETRO	1	22000258
2	B000960208000021C	ARANDELA 8 MM.	4	11048172
3	B061700006000061C	TUERCA M6	2	11048211
4	07002-L3L6-0000	SWICHE ENCENDIDO COMPLETO	1	22000226
5	B0007001050012700	TORNILLO 5X12	1	11048148
6	B057830006002071C	TORNILLO 6X20	2	11048189
7	B0009300060000U1C	ARANDELA DE PRESIÓN 6 MM.	4	11048155
8	B0007001050022700	TORNILLO 5X20	3	11048149
9	B057830006002571C	TORNILLO 8X25	2	11048190
10	B000960206000021C	ARANDELA 6 MM.	4	11052679

FIGURA N° 15: MANUBRIO - COMANDOS - ESPEJOS

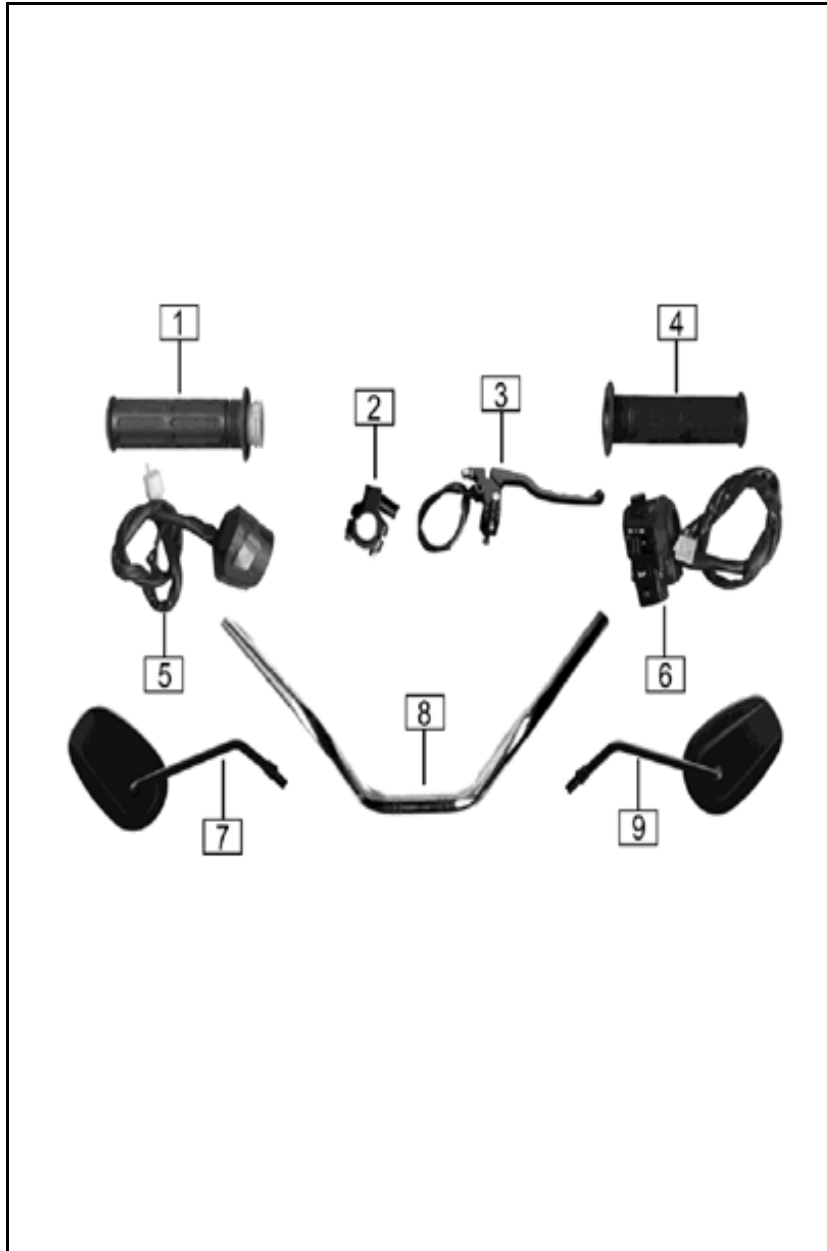

FIG. No.	PARTE N°	DESCRIPCIÓN	CANT.	SAP
1	72020-L1A8-0000	MANILLAR ACELERADOR	1	22000143
2	72317-L1A8-0000	SOPORTE ESPEJO DERECHO	1	22000145
3	72200-J1A4-0000	SOPORTE Y LEVA CLUTCH	1	22000144
4	72010-L1A8-0000	MANILLAR IZQUIERDO	1	22000142
5	84500-L1A8-0200	COMANDO DERECHO	1	22000147
6	84400-L1A8-0200	COMANDO IZQUIERDO	1	22000146
7	69120-L1A8-0000	ESPEJO DERECHO	1	22000125
8	72101-L1B1-0000	MANUBRIO	1	22000250
9	69110-L1A8-0000	ESPEJO IZQUIERDO	1	22000124

FIGURA N° 16: PEDAL CAMBIOS - PEDAL FRENO

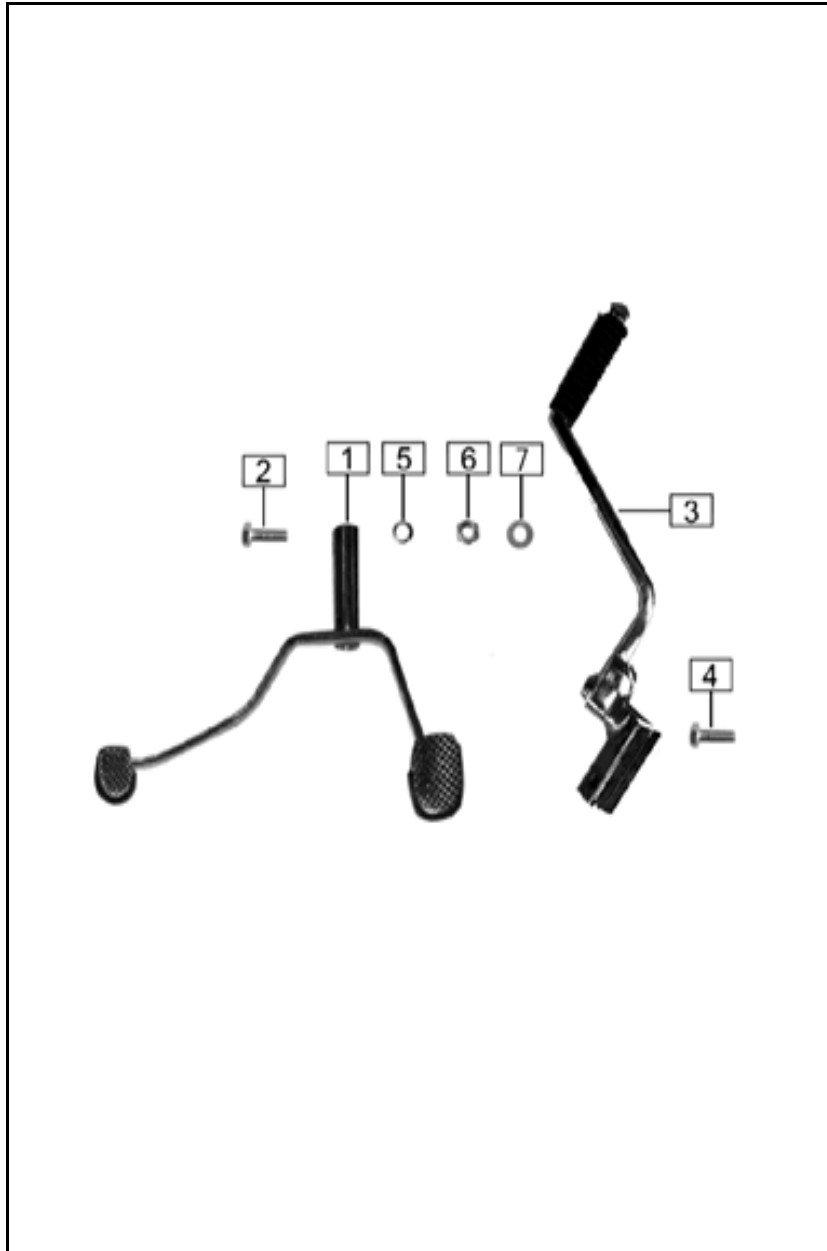

FIG. No.	PARTE N°	DESCRIPCIÓN	CANT.	SAP
1	24400-L1A8-0100	PEDAL CAMBIOS	1	22000119
2	B057830008003071C	TORNILLO 8X30	1	11048202
3	21200-J1A4-0000	PEDAL CRANK	1	22000118
4	B057830008002571C	TORNILLO 8X25	1	11048199
5	B0009300080000U1C	ARANDELA DE PRESIÓN 8 MM.	1	11048157
6	B061700008000061C	TUERCA M8	1	11048213
7	B000950008000021C	ARANDELA 8 MM.	1	11048166

FIGURA N° 17: LLANTAS - RINES

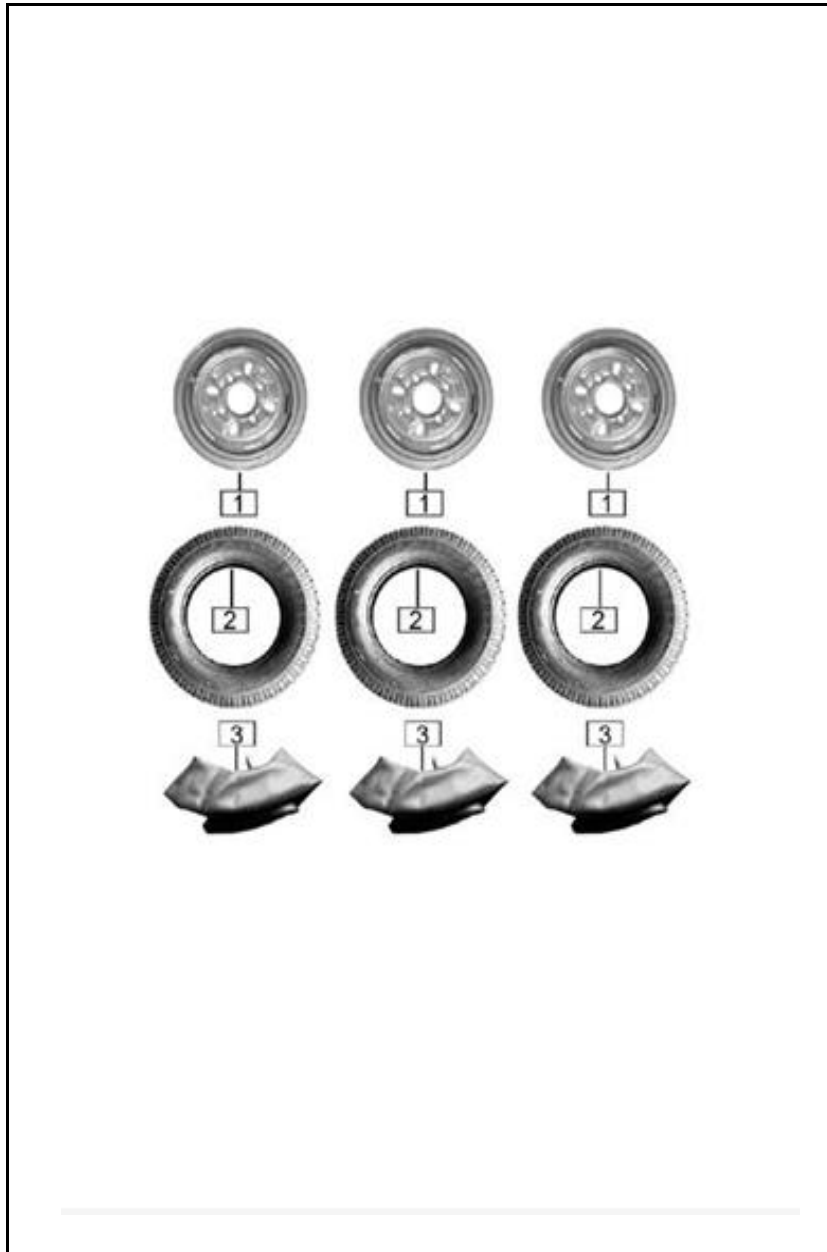

FIG. No.	PARTE N°	DESCRIPCIÓN	CANT.	SAP
1	51220-L3L6-0000	RIN DELANTERO-TRASERO	3	22000246
2	450-12-H179-TT-Q	LLANTA 4.50X12-TT(MARCA QUEEN)	3	11033558
3	450-12-RIDER	NEUMÁTICO 4.50X12(MARCA RIDER)	3	11047212

FIGURA N° 18: FRENO DELANTERO

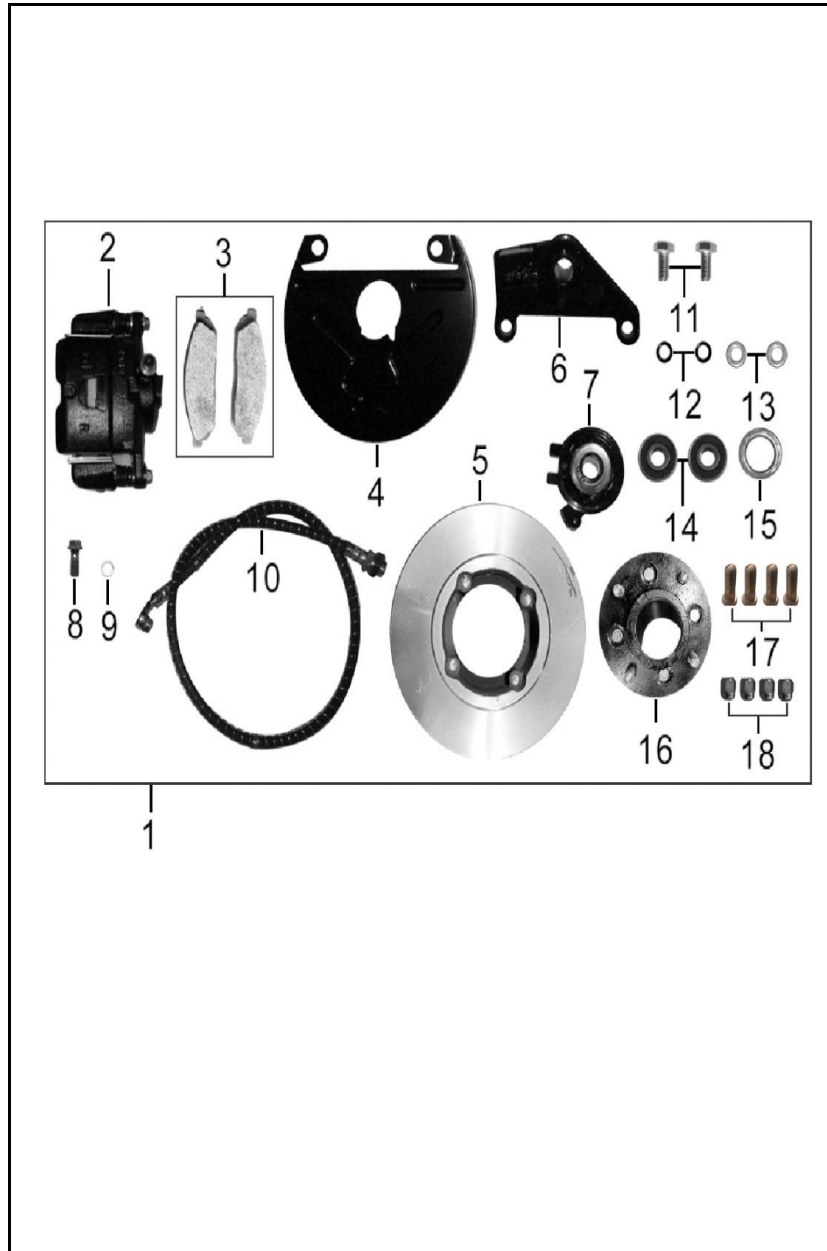

FIG. No.	PARTE N°	DESCRIPCIÓN	CANT.	SAP
1	53000-L3L6-0000	CONJUNTO FRENO DELANTERO COMPLETO	1	22000122
2	53019-L1A8-0000	CALIPER DELANTERO	1	11048043
3	54130-L1A8-0000	PASTAS FRENO DELANTERO	1	11040615
5	53001-L1A8-0001	DISCO FRENO DELANTERO	1	11048039
6	53016-L1A8-0000	SOPORTE CALIPER DELANTERO	1	11048042
7	87330-L1A8-0000	CAJA PIÑÓN VELOCÍMETRO	1	22000123
8	53008-L1A8-0000	TORNILLO MANGUERA FRENO	2	11048040
9	53009-L1A8-0000	ARANDELA DE SELLADO	4	11048041
10	5410A-L3L6-0000	MANGUERA FRENO DELANTERO	1	11048045
11	B057820012002570C	TORNILLO 12X25	2	11048185
12	B0009300120000U0H	ARANDELA 12 MM.	2	11048160
13	B00095001200002OC	ARANDELA 12 MM.	2	11048171
14	71200-6304-2RS	RODAMIENTO BOLAS 6304-2RS	2	11048088
15	90300-30524	RETEN 30-52-4	1	11048141
16	54159-L1A8-0000	BOCIN	1	11084765
17	5421F-M4E3-000001	TORNILLO FRENO DE DISCO DELANTERO	4	11084766
18	51134-M4E3-000001	TUERCA FRENO DE DISCO DELANTERO	4	11084767

FIGURA N° 19: GUARDABARRO DELANTERO - GUARDABARRO TRASERO

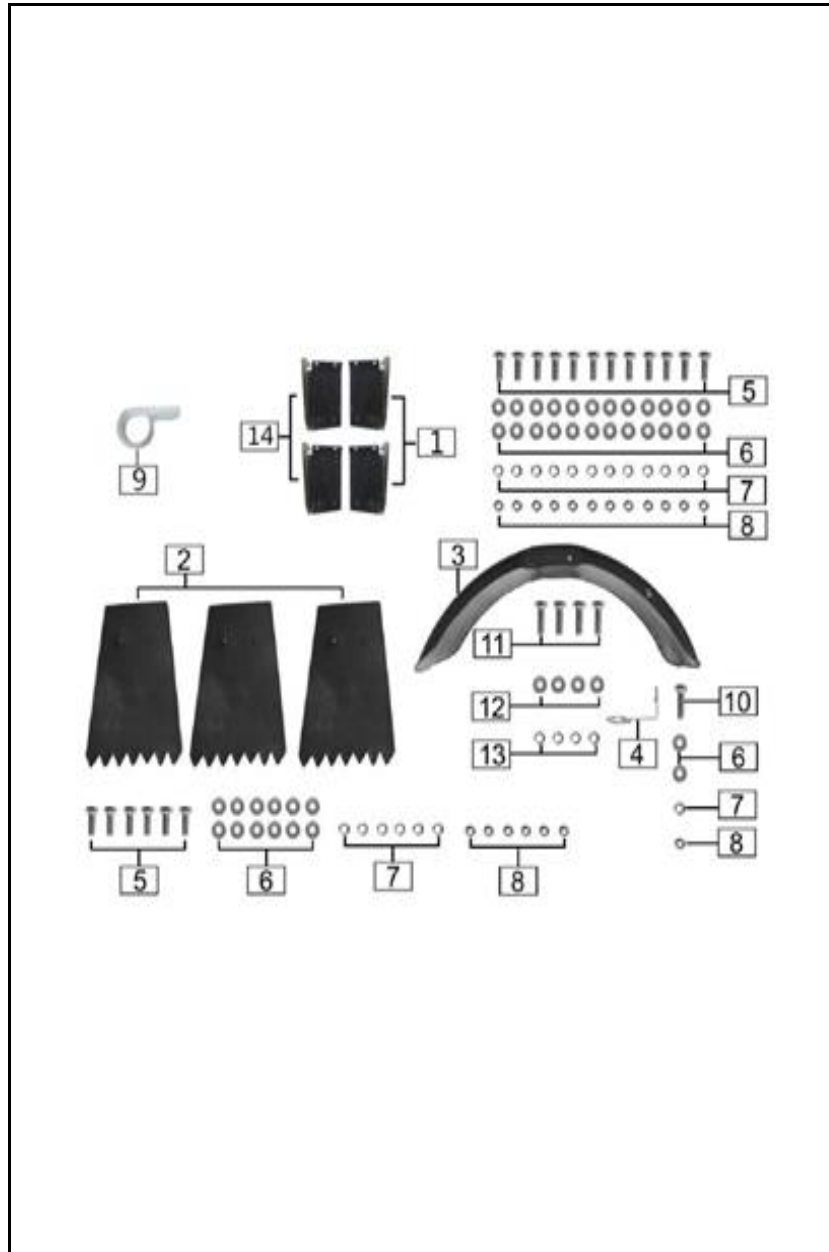

FIG. No.	PARTE N°	DESCRIPCIÓN	CANT.	SAP
1	63201-L3L6-0000	GUARDABARRO TRASERO	2	22000236
2	63102-K1S1-0100	GUARDAPOLVO RUEDA TRASERA	3	22000215
3	63104-L3L6-000000	GUARDABARRO DELANTERO	1	22000895
4	63111-0000-00000C	PLATINA	1	22000201
5	B057830006001671C	TORNILLO 6X16	18	11048187
6	B000960206000021C	ARANDELA 6 MM.	38	11052679
7	B0009300060000U1C	ARANDELA DE PRESION 6 MM.	19	11048155
8	B061700006000061C	TUERCA M6	19	11048211
9	31168-R0D4-0000	ABRAZADERA	2	22000186
10	B057830006002071C	TORNILLO 6X20	1	11048189
11	B057830008001671C	TORNILLO 8X16	4	11048195
12	B000950008000021C	ARANDELA 8 MM.	4	11048166
13	B0009300080000U1C	ARANDELA DE PRESION 8 MM.	4	11048157
14	63202-L3L6-0000	GUARDABARRO TRASERO	2	22000237

FIGURA N° 20: SUSPENSIÓN DELANTERA

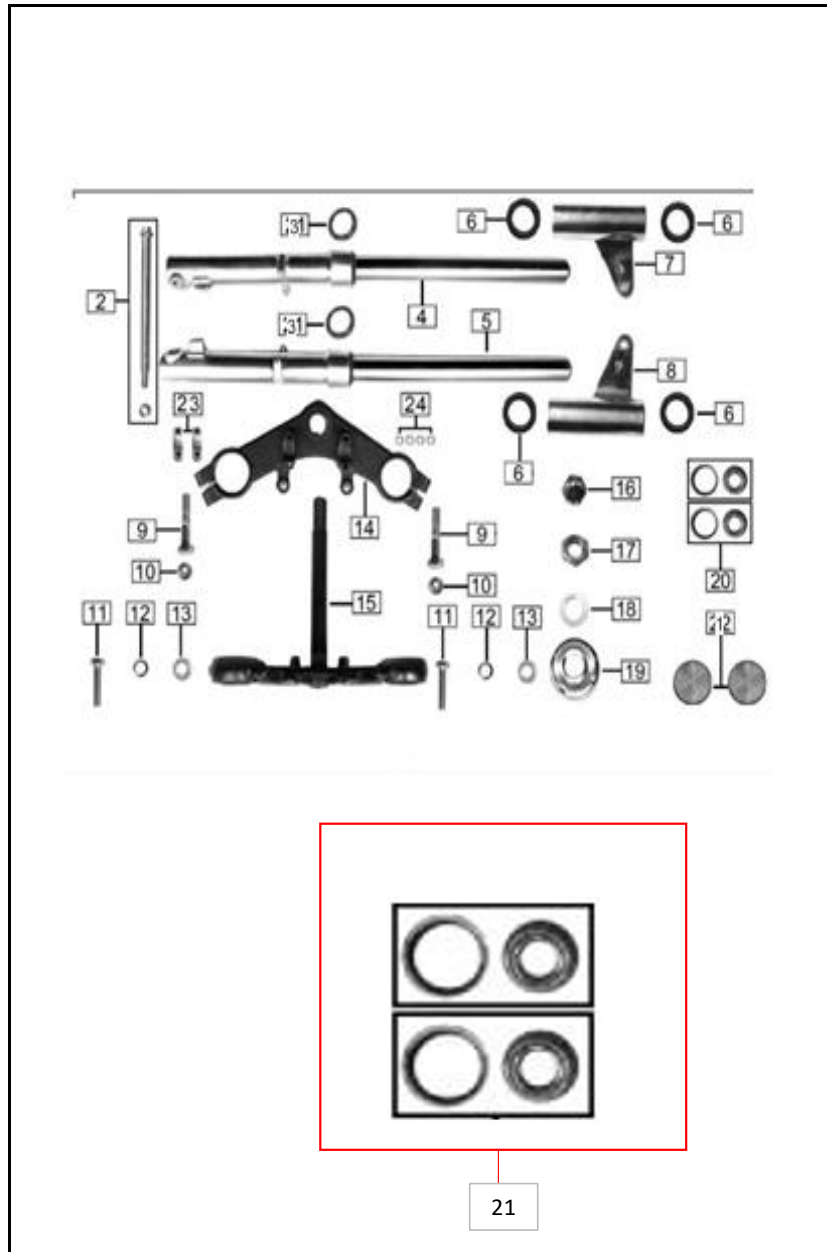

FIG. No.	PARTE N°	DESCRIPCIÓN	CANT.	SAP
1	85850-H259-C100	REFLECTIVO FRONTAL LATERAL	2	22000180
2	51181-L3L6-0000	EJE RUEDA DELANTERA 20X305	1	22000135
3	34107-L1A8-0000	RETEN TUBO TELESCÓPICO 63-50-11	2	11040627
4	34100-L1A8-0100	TUBOTELESCÓPICO IZQ.COMPL.	1	22000239
5	34200-L1A8-0100	TUBOTELESCÓPICO DER. COMPL.	1	22000238
6	86196-L1A8-0100	CAUCHO SOPORTE FAROLA	4	22000210
7	8619G-L1A8-0100	SOPORTE FAROLA DERECHO	1	22000208
8	8619F-L1A8-0100	SOPORTE FAROLA IZQUIERDO	1	22000209
9	B057830010006071C	TORNILLO 10X60	2	11048208
10	B061700010000061C	TUERCA M10	2	11048215
11	B057830010004071C	TORNILLO 10X40	2	11048207
12	B0009300100000U1C	ARANDELA DE PRESIÓN 10 MM.	2	11048158
13	B000950010000021C	ARANDELA 10 MM.	2	11048168
14	71101-L1A8-00001C	CABEZA ESPIGA	1	22000134
15	7110A-L1A8-00001C	ESPIGA CENTRAL	1	22000129
16	71104-L1A8-0000	TUERCA TAPÓN CABEZA ESPIGA	1	22000130
17	71106-L1A8-00001C	TUERCA CABEZA ESPIGA	1	22000131
18	71123-L1A8-00001C	ARANDELA CABEZA ESPIGA	1	22000132
19	71105-L1A8-00001C	TUERCA DIRECCIÓN	1	22000133
20	71200-30205	RODAMIENTO BOLAS	2	22000163
21	22000163	KIT CUNAS	1	22000163

FIGURA N° 21: TANQUE GASOLINA

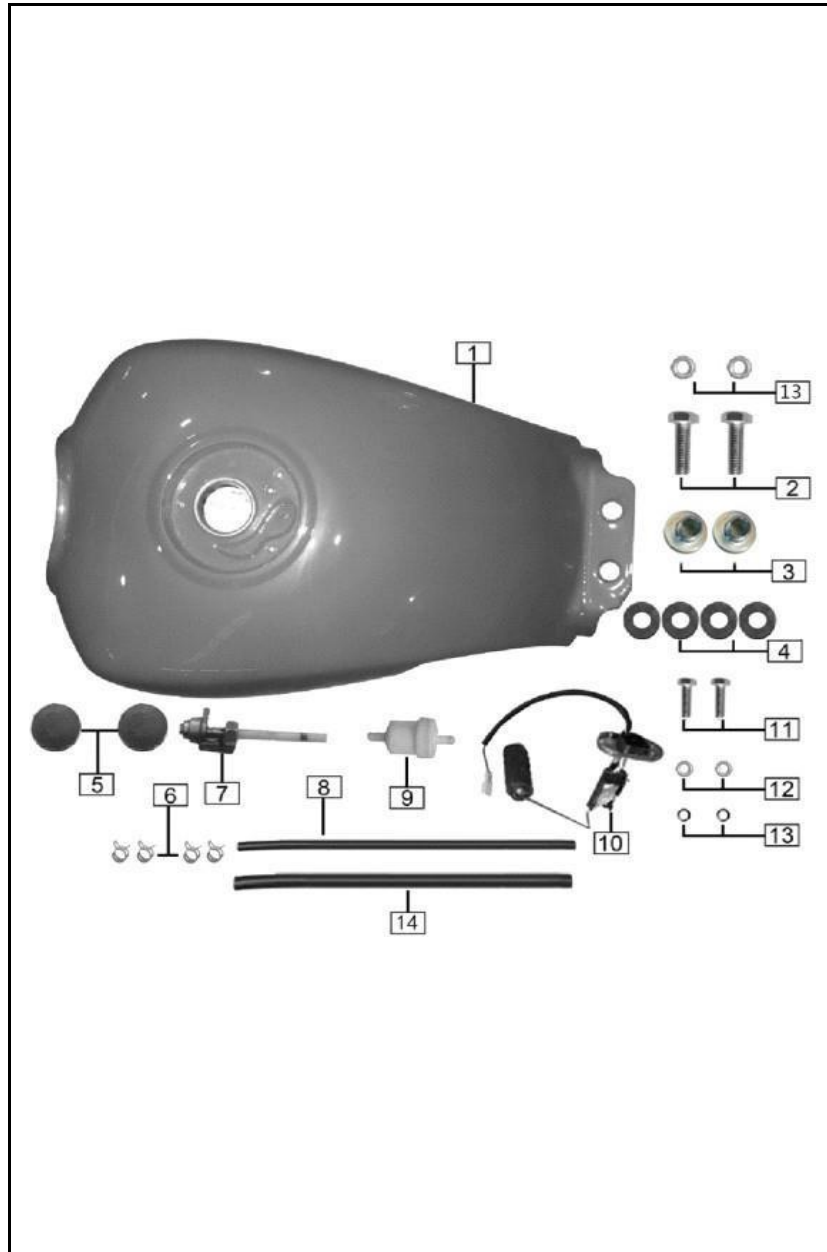

FIG. No.	PARTE N°	DESCRIPCIÓN	CANT.	SAP
1	61100-L3L6-0051PK	TANQUE GASOLINA(GRIS)	1	22000285
	61100-L3L6-00494C	(BLANCO)	1	22000173
	61100-L3L6-005065	(NEGRO)	1	22000282
2	B057830006002571C	TORNILLO 6X25	2	11048190
3	91302-0060-20091X	BUJE 6X20X9	2	22000170
4	61121-1126-0200	ANTIVIBRANTE TANQUE GASOLINA	4	22000197
5	61111-1126-0200	TAPÓN TANQUE GASOLINA	2	22000196
6	91404-M1B5-07521C	ABRAZADERA	4	22000202
7	61300-J1A4-0000	GRIFO GASOLINA	1	22000198
8	61301-0000-0500	MANGUERA GASOLINA	1	22000199
9	61400-L1A8-0000	FILTRO GASOLINA	1	22000200
10	87200-J1U8-0000	MEDIDOR TANQUE GASOLINA	1	22000174
11	B057830006002071C	TORNILLO 6X20	2	11048189
12	B000950006000021C	ARANDELA 6 MM.	2	11048163
13	B0009300060000U1C	ARANDELA DE PRESIÓN 6 MM.	2	11048155
14	19227-L1A8-0100	MANGUERA GASOLINA	1	22000175

FIGURA N° 22: COMPLEMENTOS CHASIS

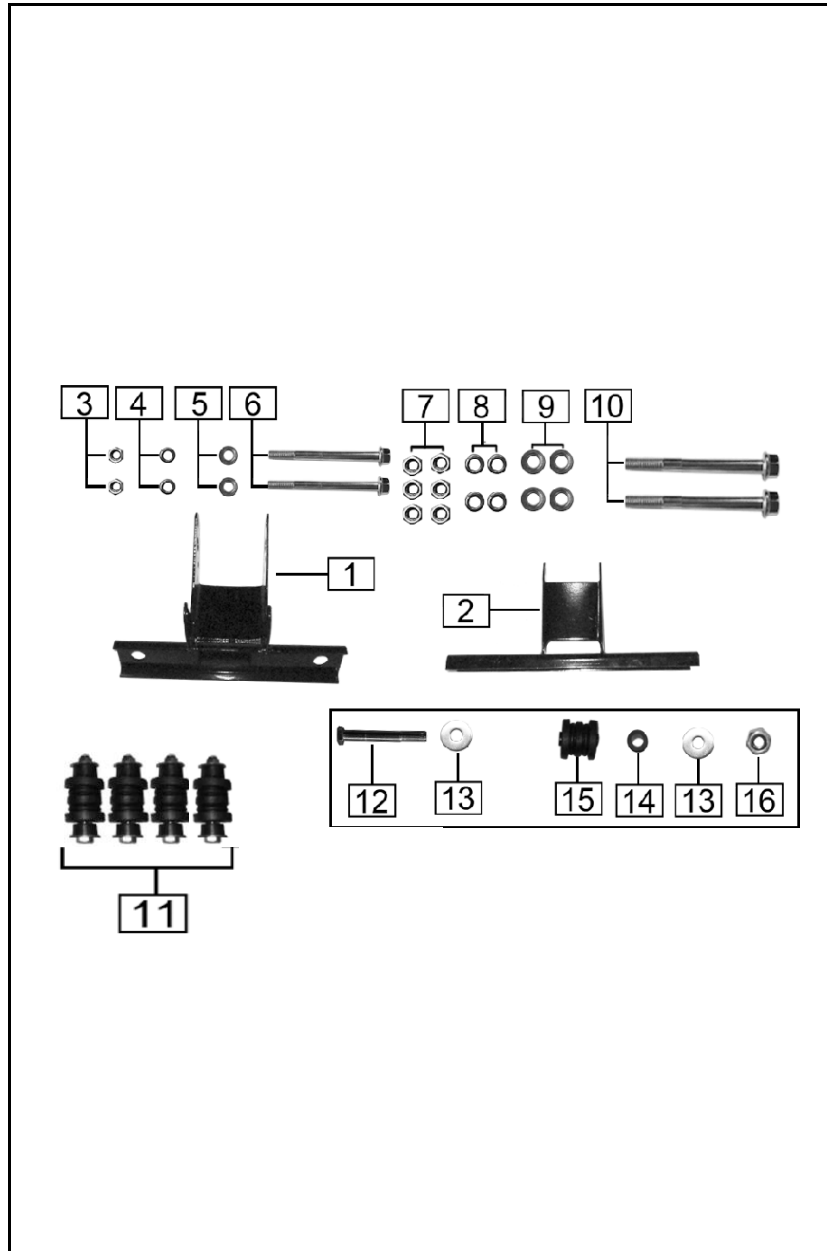

FIG. No.	PARTE N°	DESCRIPCIÓN	CANT.	SAP
1	32310-L3L6-0000	SOPORTE FRONTAL MOTOR	1	22000252
2	32320-L3L6-0000	SOPORTE TRASERO MOTOR	1	22000253
3	B000950008000021C	ARANDELA 8 MM.	2	11048166
4	B0009300080000U1C	ARANDELA DE PRESIÓN 8 MM.	2	11048157
5	B061700008000061C	TUERCA M8	2	11048213
6	B0578200080095S1C	TORNILLO 8X95	2	11048183
7	B061700010000061C	TUERCA M10	6	11048215
8	B0009300100000U1C	ARANDELA DE PRESIÓN 10 MM.	4	11048158
9	B000950010000021C	ARANDELA 10 MM.	4	11048168
10	B0578200100150S1C	TORNILLO 10X50	2	11048184
11	32300-L3L6-00001C	RESORTE SOPORTE MOTOR	4	22000203

FIGURA N° 23: SILLÍN

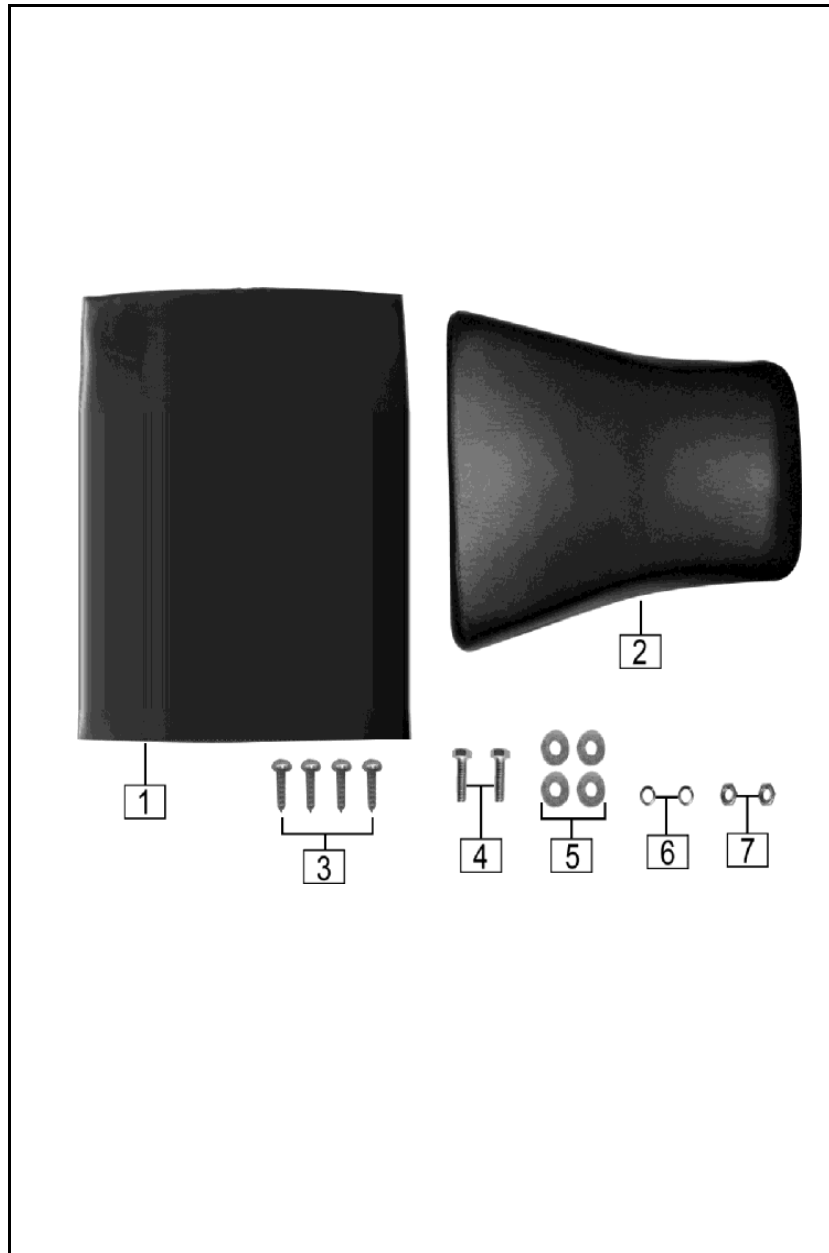

FIG. No.	PARTE N°	DESCRIPCIÓN	CANT.	SAP
1	41400-J1U8-0100	ESPALDAR SILLÍN	1	22000255
2	41200-J1U8-0000	SILLÍN	1	22000254
3	B0084500048020A1C	TORNILLO 4.8X20	4	11048176
4	B057830008002571C	TORNILLO 8X25	2	11048199
5	B000960208000021C	ARANDELA 8 MM.	4	11048172
6	B0009300080000U1C	ARANDELA DE PRESIÓN 8 MM.	2	11048157
7	B061700008000061C	TUERCA M8	2	11048213

FIGURA N° 24: CAUCHO REPOSAPIE

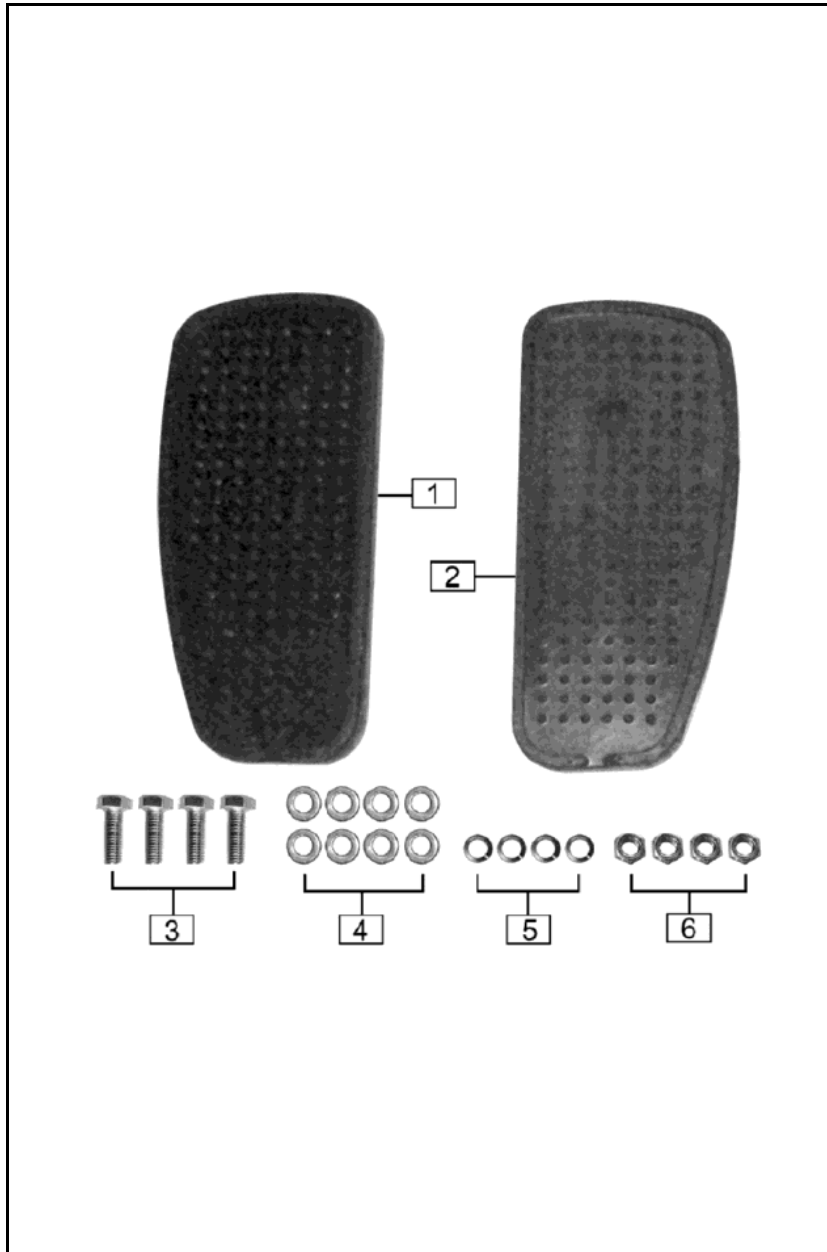

FIG. No.	PARTE N°	DESCRIPCIÓN	CANT.	SAP
1	32106-L3L6-0000	CAUCHO REPOSAPIE IZQUIERDO	1	22000189
2	32107-L3L6-0000	CAUCHO REPOSAPIE DERECHO	1	22000190
3	B057830008002571C	TORNILLO 8X25	4	11048199
4	B000960208000021C	ARANDELA 8 MM.	8	11048172
5	B0009300080000U1C	ARANDELA DE PRESIÓN 8 MM.	4	11048157
6	B061700008000061C	TUERCA M8	4	11048213

FIGURA N° 25: TAPAS LATERALES

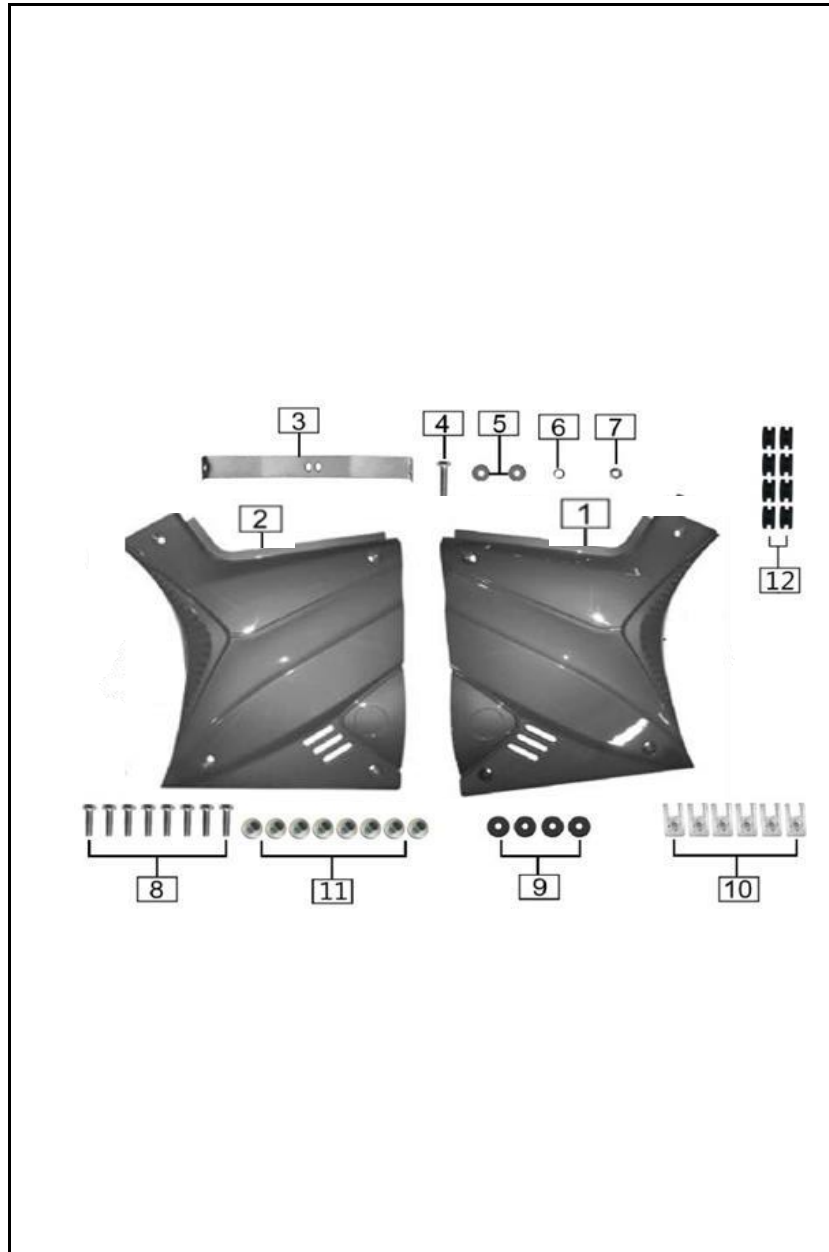

FIG. No.	PARTE N°	DESCRIPCIÓN	CANT.	SAP
1	63302-J1U8-0051PK	TAPA LATERAL DERECHA(GRIS)	1	22000286
	63301-J1U8-00494C	TAPA LATERAL DERECHA BLANCA	1	22000240
	63302-J1U8-005065	TAPA LATERAL DERECHA NEGRA	1	22000283
2	63301-J1U8-0051PK	TAPA LATERAL IZQUIERDA(GRIS)	1	22000287
	63302-J1U8-00494C	TAPA LATERAL IZQUIERDA BLANCA	1	22000241
	63301-J1U8-005065	TAPA LATERAL IZQUIERDA NEGRA	1	22000284
3	63303-L3L6-00000C	SOPORTE TAPA LATERAL DERECHA	1	22000207
4	B057830006002571C	TORNILLO 6X25	2	11048190
5	B000960206000021C	ARANDELA 6 MM.	4	11052679
6	B0009300060000U1C	ARANDELA DE PRESIÓN 6 MM.	2	11048155
7	B061700006000061C	TUERCA M6	2	11048211
8	9A114-1060-02571C	TORNILLO 6X25	8	11048146
9	61121-1126-0200	ANTIVIBRANTE TANQUE GASOLINA	4	22000197
10	91206-1060-03521C	ARANDELA DE AJUSTE M6	8	11048142
11	91302-9060-18081C	BUJE	8	22000171
12	6222B-0000-1200	ANTIVIBRANTE	8	22000185

FIGURA N° 26: SILENCIADOR

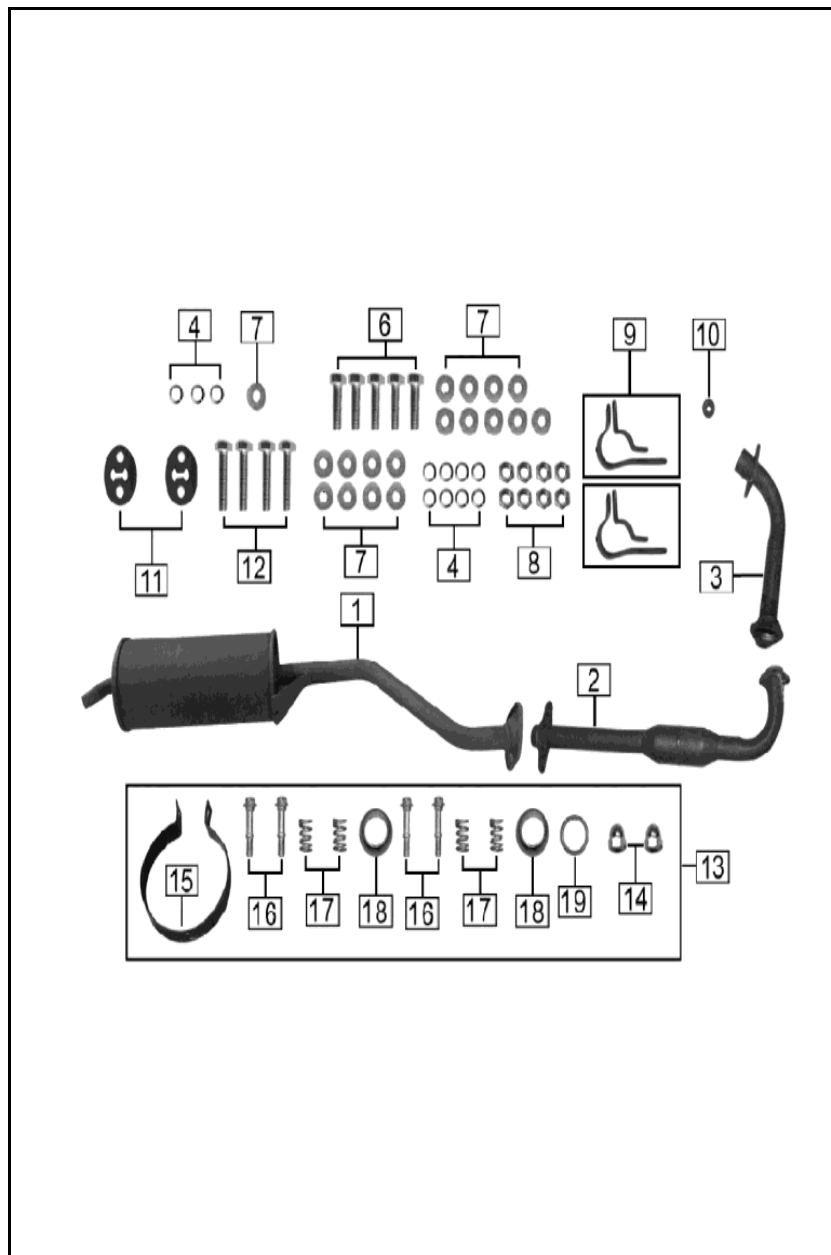

FIG. No.	PARTE N°	DESCRIPCIÓN	CANT.	SAP
1	18200-L1A8-010066	SILENCIADOR	1	22000249
2	1806M-L3L6-000066	TUBO ESCAPE CON CATALIZADOR	1	22000248
3	18100-L3L6-000066	EXTENSIÓN TUBO ESCAPE	1	22000247
4	B0009300080000U1C	ARANDELA DE PRESIÓN 8 MM.	9	11048157
5	18001-L1A8-0000	EMPAQUE TUBO ESCAPE	1	22000221
6	B057830008003071C	TORNILLO 8X30	5	11048202
7	B000960208000021C	ARANDELA 8 MM.	17	11048172
8	B061700008000061C	TUERCA M8	8	11048213
9	18011-L1B3-000001	PLATINA SILENCIADOR	2	22000899
10	18104-L1A8-0000	ANTIVIBRANTE	1	22000223
11	18006-L1A8-0100	ANTIVIBRANTE	2	22000217
12	B057830008004071C	TORNILLO 8X40	4	11048203
13	1800A-L3L6-0000	SET MONTAJE SILENCIADOR	1	11047917
14	B061770110000060C	TUERCA M10	2	22000218
15	1804E-0000-0000	ABRAZADERA	1	11047919
16	18003-J1A4-0000	TORNILLO 10X52	4	22000219
17	18004-L1A8-0000	RESORTE	4	22000220
18	18005-J1A4-0000	EMPAQUE TUBO ESCAPE	2	22000222

FIGURA N° 27: PEDAL FRENO - VARILLA FRENO TRASERO

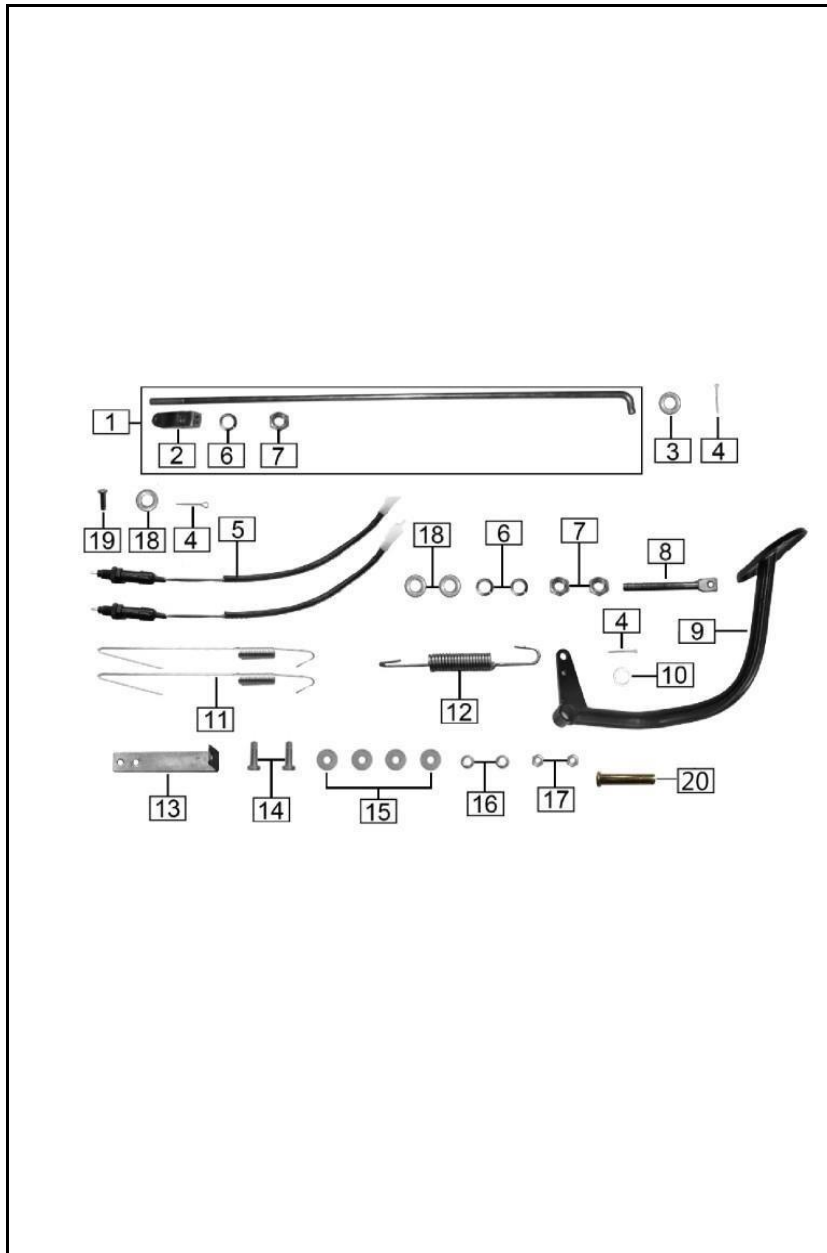

FIG. No.	PARTE N°	DESCRIPCIÓN	CANT.	SAP
1	52131-L3L6-00000C	VARILLA FRENO	2	22000256
2	24430-0000-00000C	ACOPLE VARILLA FRENO	1	11047933
3	B000950010000021C	ARANDELA 10 MM.	1	11048168
4	B000910002503021C	PIN DE SEGURIDAD 2.5X30	2	11048151
5	85720-L1A8-0000	SWICHE STOP	2	22000213
6	B0009300080000U0C	ARANDELA 8 MM.	3	11048156
7	B061700008000060C	TUERCA M8	3	11048212
8	52106-0000-00000C	EJE AJUSTE PEDAL FRENO	1	
9	52120-L3L6-0000	PEDAL FRENO	1	11048028
10	91301-91702023421C	ARANDELA 17 MM.	1	11048143
11	84701-L1A8-00000C	RESORTE SWICHE STOP	2	22000166
12	52104-0000-01000C	RESORTE PEDAL FRENO	1	22000164
13	31013-0000-01000C	SOPORTE SWICHE STOP	1	11047936
14	B057830006002071C	TORNILLO 6X20	2	11048189
15	B000960206000021C	ARANDELA 6 MM.	4	11052679
16	B0009300060000U1C	ARANDELA DE PRESIÓN 6 MM.	2	11048155
17	B061700006000061C	TUERCA M6	2	11048211
18	B000950008000021C	ARANDELA 8 MM.	2	11048166
19	B0088200080022T1C	PIN PASADOR 8X20	1	22000901
20	52101-J1A4-0000	PIN PASADOR PEDAL FRENO 17X83	1	22000121

FIGURA N° 28: PALANCA DE REVERSA - STOP

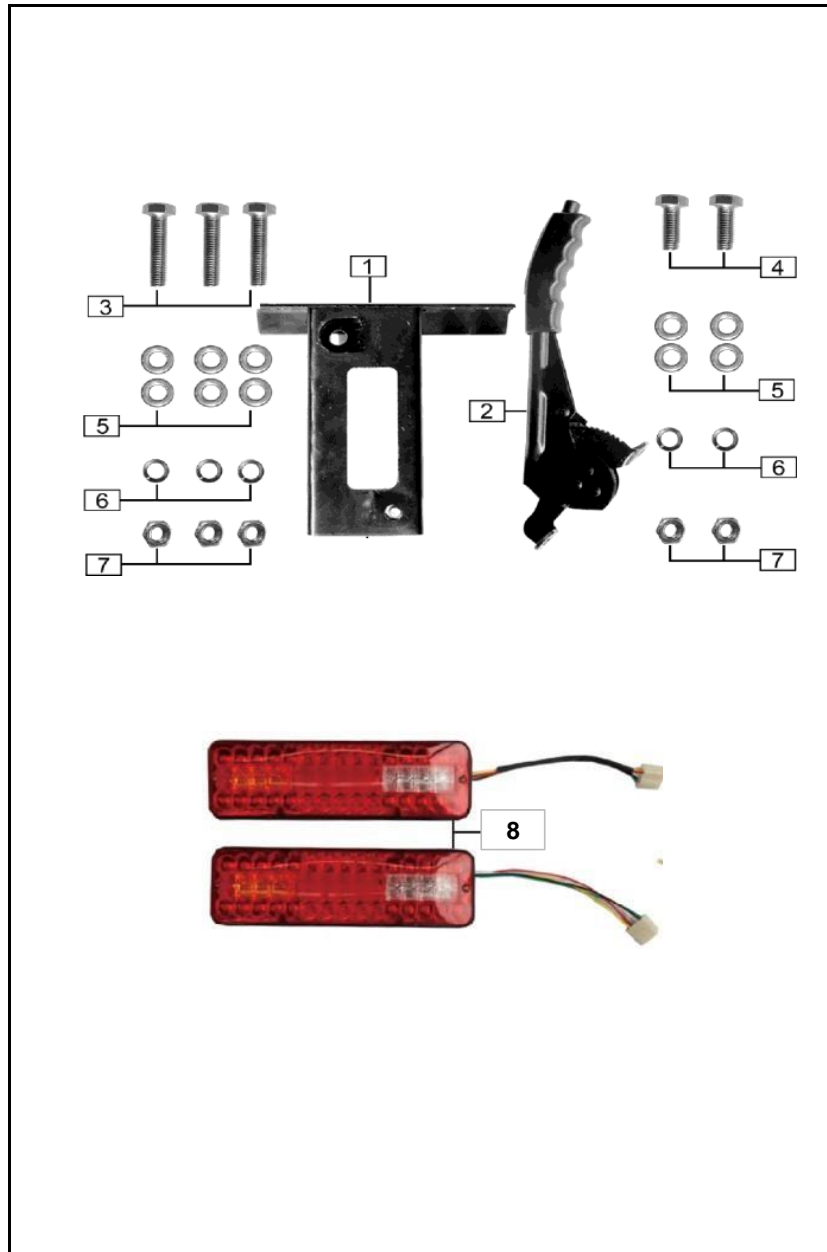

FIG. No.	PARTE N°	DESCRIPCIÓN	CANT.	SAP
1	31212-L3L6-0000	SOPORTE PALANCA DE REVERSA	1	22000178
2	52220-L1A8-0100	PALANCA DE REVERSA	1	22000136
3	B057830008006071C	TORNILLO 8X60	3	11048205
4	B057830008002571C	TORNILLO 8X25	2	11048199
5	B000950008000021C	ARANDELA 8 MM.	10	11048166
6	B0009300080000U1C	ARANDELA DE PRESIÓN 8 MM.	5	11048157
7	B061700008000061C	TUERCA M8	5	11048213
8	86200-L1B3-0100	STOP	2	22000259

FIGURA N° 29: PALANCA CONTROL TRACCIÓN

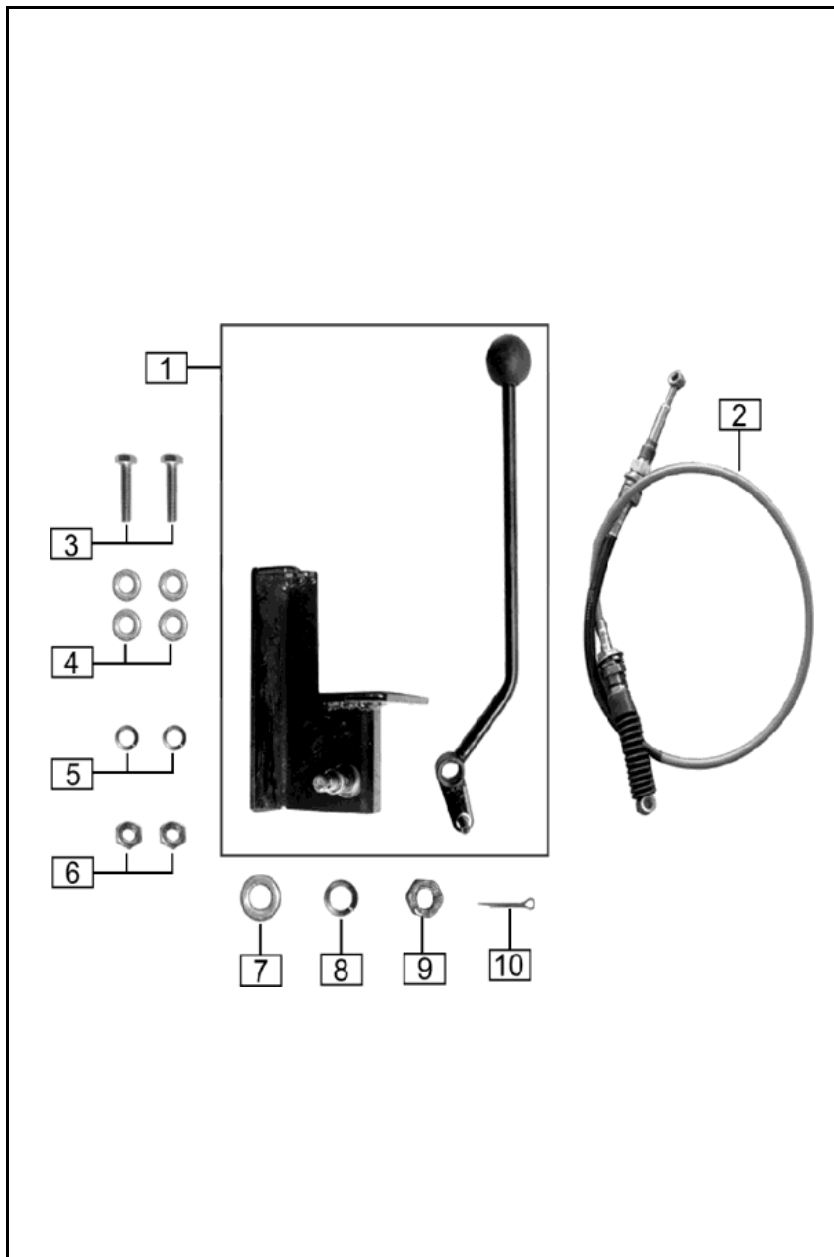

FIG. No.	PARTE N°	DESCRIPCIÓN	CANT.	SAP
1	24504-L1A8-0000	PALANCA CONTROL TRACCIÓN	1	22000235
2	24507-L3L6-00001C	CABLE CAMBIO MARCHA	1	22000266
3	B057830008006070C	TORNILLO 8X60	2	11048204
4	B000950008000020C	ARANDELA 8 MM.	4	11048165
5	B0009300080000U0C	ARANDELA 8 MM.	2	11048156
6	B061700008000060C	TUERCA M8	2	11048212
7	B000950012000020C	ARANDELA 12 MM.	1	11048169
8	B0009300120000U0C	ARANDELA DE PRESIÓN 12 MM.	1	11048159
9	B061700012000060C	TUERCA M12	1	11048216
10	B000910002503020C	PIN PASADOR 2.5X30	1	11048150

FIGURA N° 30: CABLES

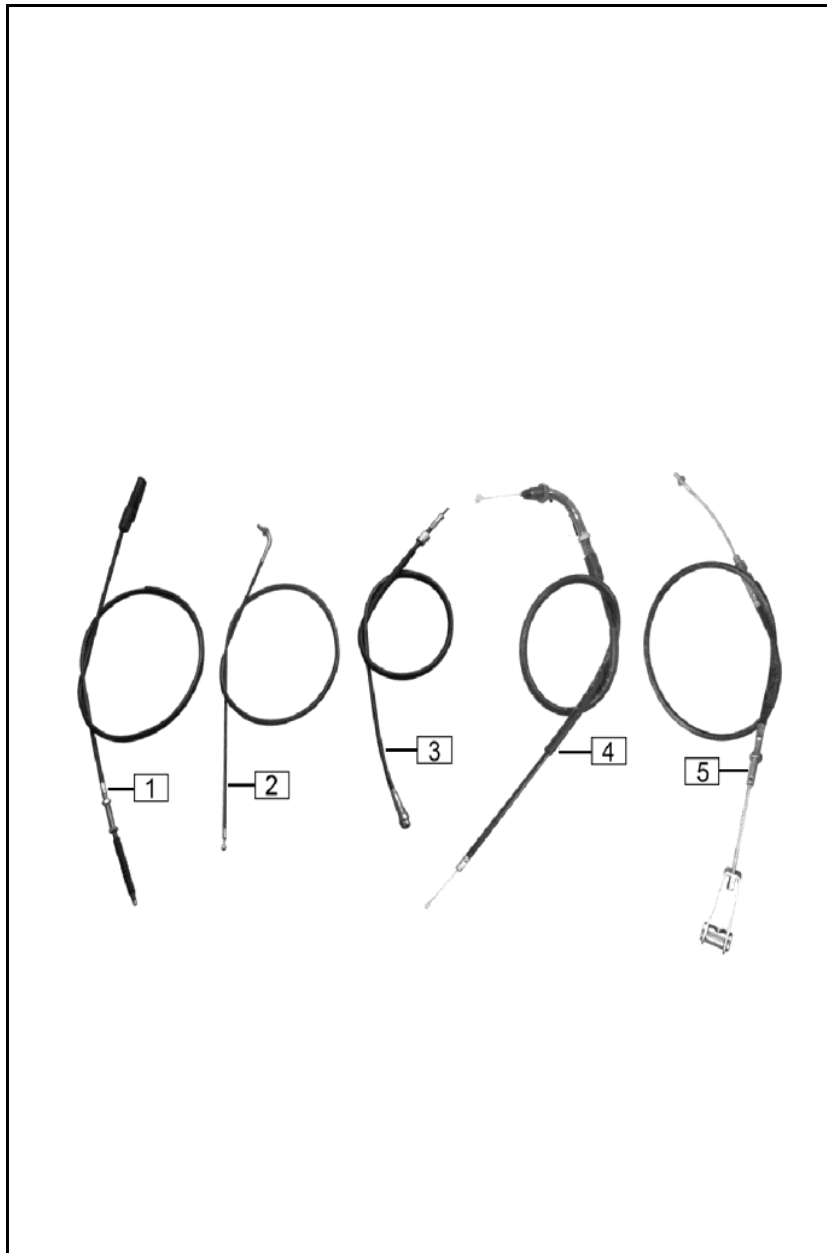

FIG. No.	PARTE N°	DESCRIPCIÓN	CANT.	SAP
1	72600-L3L6-00001C	CABLE CLUTCH	1	22000261
2	72700-J1A4-00001C	CABLE CHOKE	1	22000262
3	87300-L3L6-00000C	CABLE VELOCÍMETRO	1	22000265
4	72400-L3L6-00001C	CABLE ACELERADOR	1	22000263
5	52230-L3L6-00001C	CABLE FRENO DE MANO	1	22000264

FIGURA N° 31: EQUIPO ELÉCTRICO

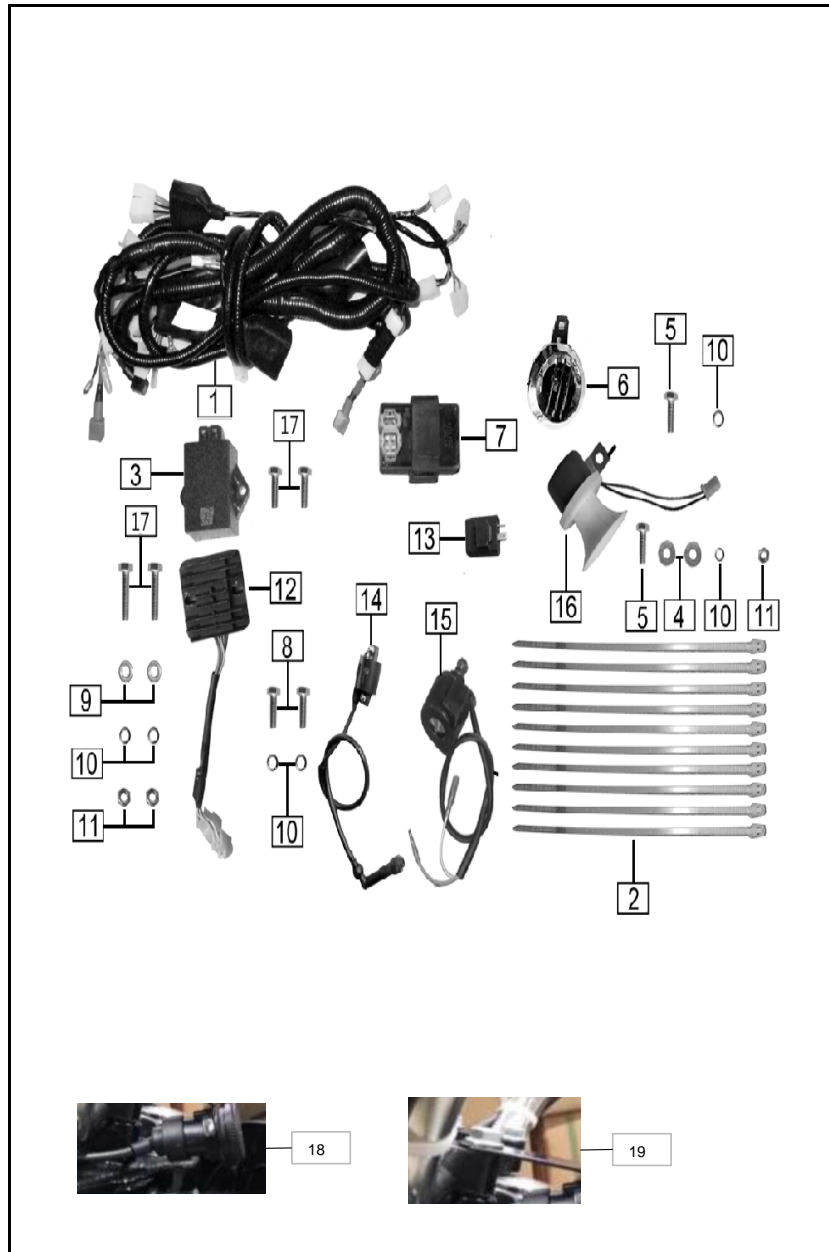

FIG. No.	PARTE N°	DESCRIPCIÓN	CANT.	SAP
1	85100-L3L6-0000	INSTALACIÓN ELÉCTRICA	1	22000260
1a	85100-L3L6-0100	RAMAL ELECTRICO (CARGADOR USB)	1	11066423
2	08216-0000-1200	CORREA DE SUJECIÓN	15	22000211
3	82310-L3L6-0000	CONTROLADOR VENTILADOR	1	22000191
4	B000960206000021C	ARANDELA 6 MM.	4	11052679
5	B057830006001671C	TORNILLO 6X16	2	11048187
6	85500-L1A8-0000	PITO	1	22000179
7	81200-L3L6-0000	C.D.I	1	22000140
7A	81200-L3L6-0100	ZS IGNICION TRI 200 (CARGADOR USB)	1	22000745
8	B057830006003071C	TORNILLO 6X30	2	11048191
9	B000950006000021C	ARANDELA 6 MM.	4	11048163
10	B0009300060000U1C	ARANDELA DE PRESIÓN 6 MM.	7	11048155
11	B061700006000061C	TUERCA M6	7	11048211
12	83100-L1A8-0000	REGULADOR(6 CABLES)	1	22000138
12A	83100-L3L6-0000	REGULADOR(5 CABLES)		22000744
12B	83100-L3L6-0000	ZS RECTIFICADOR TRI 200 (CARGADOR USB)	1	22000744
13	85600-J1A4-0000	FLASHER	1	22000141
14	81100-J1A4-0000	BOBINA DE ALTA	1	22000137
15	82290-L1A8-0000	RELAY ARRANQUE	1	22000139
16	85700-J1A4-0000	BOCINA DE REVERSA	1	22000806
17	B057830006002571C	TORNILLO 6X25	3	11048190
18	82400-0000-0200	CARGADOR USB	1	22000749
19	8121B-I126-C0006N	FIJACIÓN CARGADOR USB	1	22000748

FIGURA N° 33: CHASIS

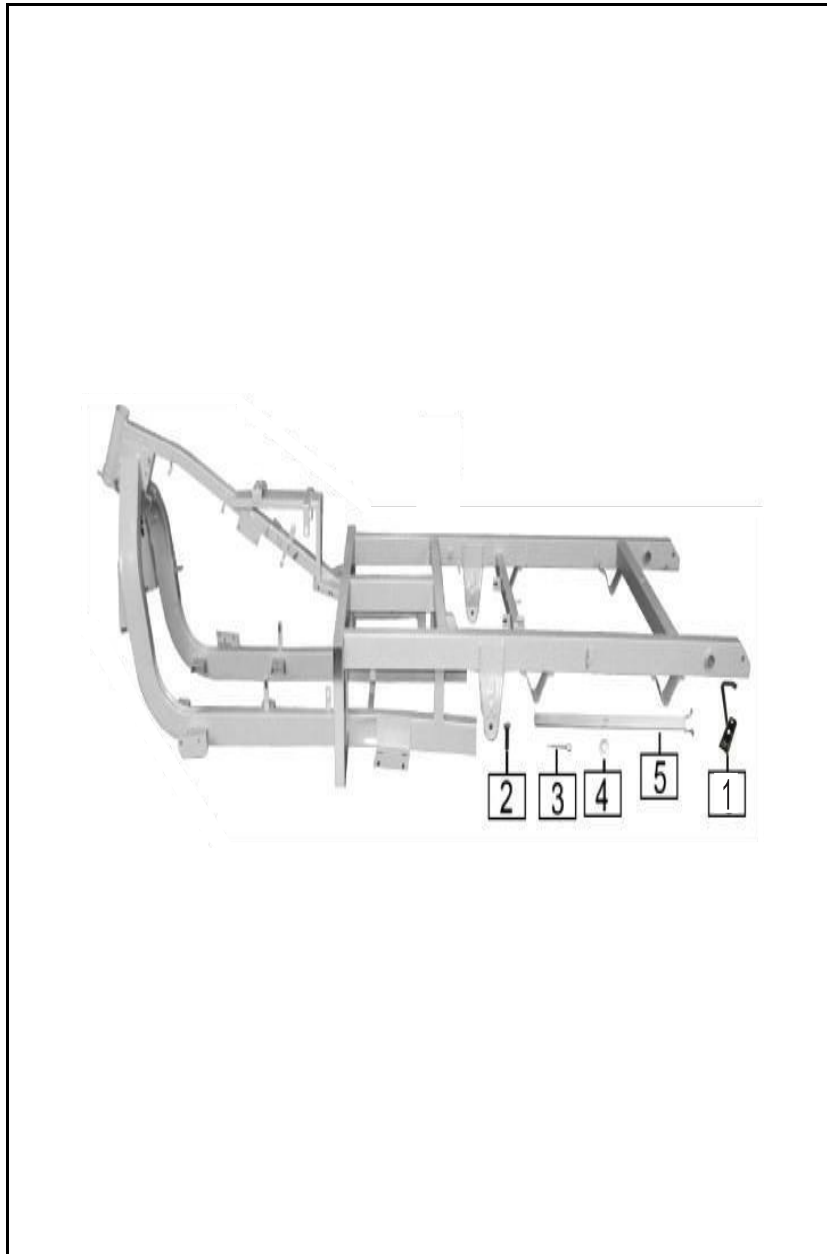

FIG. No.	PARTE N°	DESCRIPCIÓN	CANT.	SAP
1	62903-L3L6-0000	SOPORTE LLANTA REPUESTO	1	22000206
2	62903-L3L6-0100	PIN PASADOR	1	11048055
3	B008820010004520C	PIN DE AJUSTE 10X45	1	11048180
4	B0009500100000K1C	ZS ARANDELA PLANA M10 TRI 200	1	22000874
5	B000910002503020C	PIN PASADOR 2.5X30	1	11048150



FIGURA N° 34: CARROCERÍA

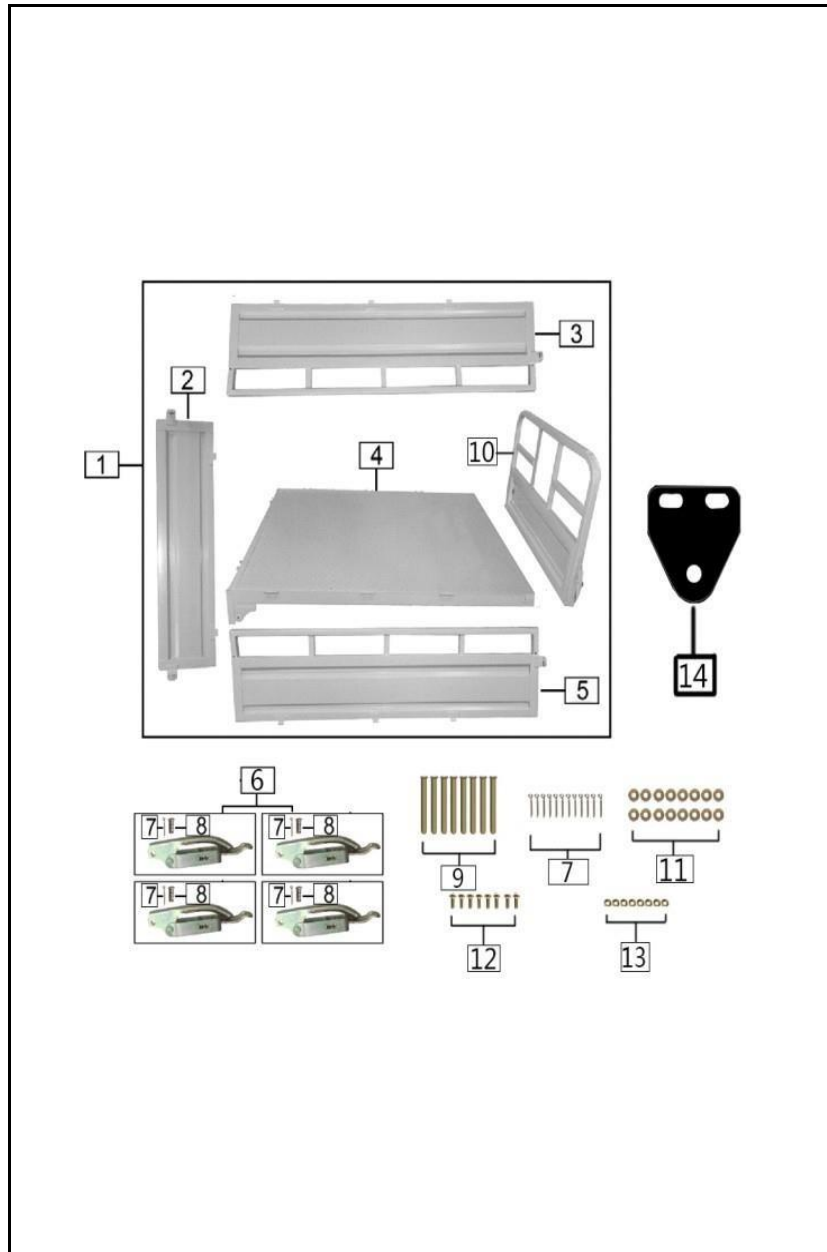

FIG. No.	PARTE N°	DESCRIPCIÓN	CANT.	SAP
1	43100-L3L6-000065	CARROCERÍA COMPLETA	1	11048019
2	63940-L3L6-000065	COMPUERTA TRASERA	1	22000276
3	63921-L3L6-000065	COMPUERTA TRASERA IZQUIERDA	1	22000274
4	63910-L3L6-000065	BASE CARGA	1	22000273
5	63922-L3L6-000065	COMPUERTA TRASERA DERECHA	1	22000275
6	43200-J1A4-0000	AGARRADERA APERTURA PUERTA	4	22000227
7	B000910002503021C	PIN DE SEGURIDAD 2.5X30	4	11048151
8	B0088200080022T1C	PIN PASADOR 8X22	4	22000901
9	B008820008008621C	PIN PASADOR 8X86	8	11048179
10	63930-L3L6-000065	BASE FRONTAL	1	22000277
11	B000950008000021C	ARANDELA 8 MM.	16	11048166
12	B057830008002571C	TORNILLO 8X25	8	11048199
13	B061700008000061C	TUERCA M8	8	11048213
14	43011-L3L6-010000	SOPORTE CARROCERÍA	4	22000896

FIGURA N° 35: COMPLEMENTOS CARROCERÍA

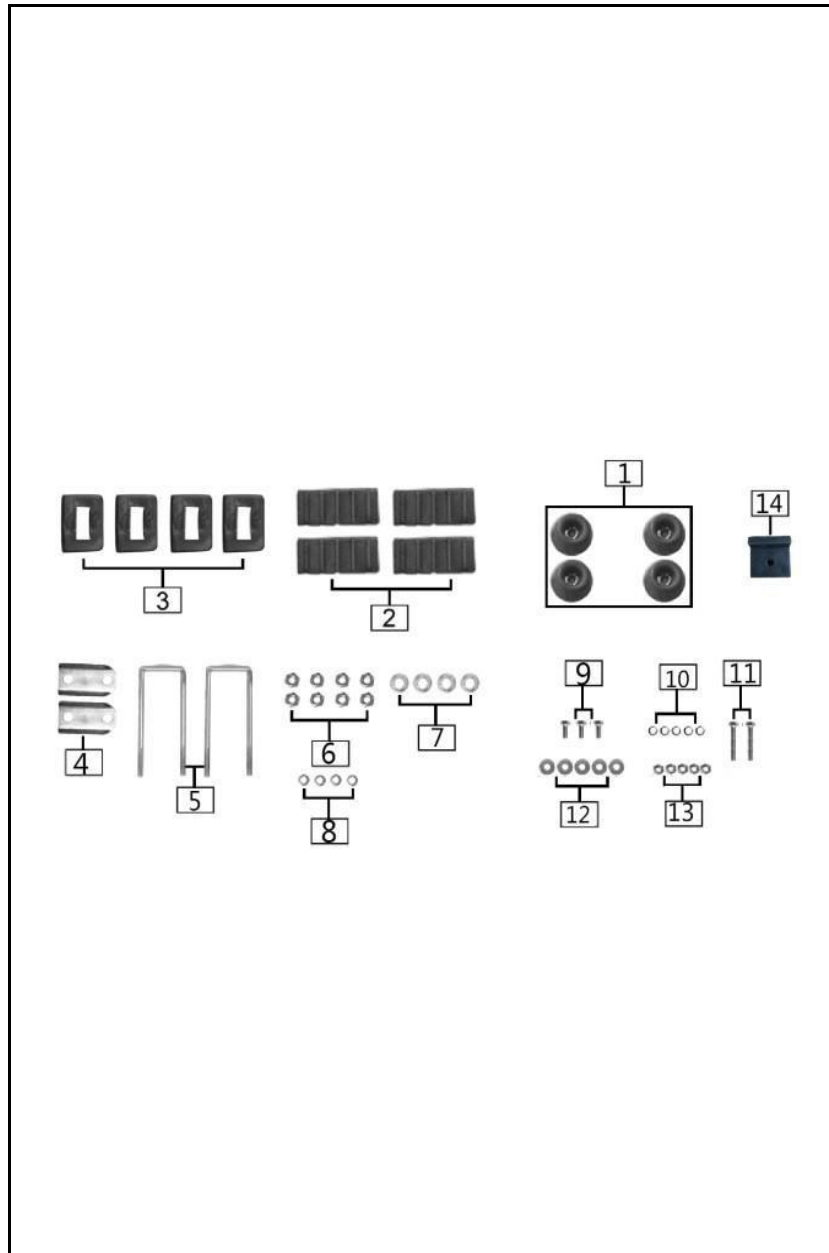

FIG. No.	PARTE N°	DESCRIPCIÓN	CANT.	SAP
1	43108-J1A4-0000	CAUCHO CARROCERÍA	4	22000182
2	43004-0000-0000	CAUCHO CARROCERÍA	4	22000187
3	43203-0000-0100	CAUCHO CARROCERÍA	4	22000183
4	43007-L1A8-00000C	PLATINA	2	22000116
5	43001-J1U8-00000C	VARILLA DE AJUSTE	2	22000115
6	B061700010000060C	ARANDELA 10 MM.	8	11048214
7	B000950010000021C	ARANDELA 10 MM.	5	11048168
8	B0009300100000U1C	ARANDELA DE PRESIÓN 10 MM.	4	11048158
9	B057830006002571C	TORNILLO 6X25	3	11048190
10	B0009300060000U1C	ARANDELA DE PRESIÓN 6 MM.	5	11048155
11	B057830006006571C	TORNILLO 6X65	2	11048193
12	B000960206000021C	ARANDELA 6 MM.	4	11052679
13	B061700006000061C	TUERCA M6	5	11048211
14	52111-K1S1-0000	ANTIVIBRANTE PEDAL FRENO	1	22000184

FIGURA N° 36: SUSPENSIÓN TRASERA

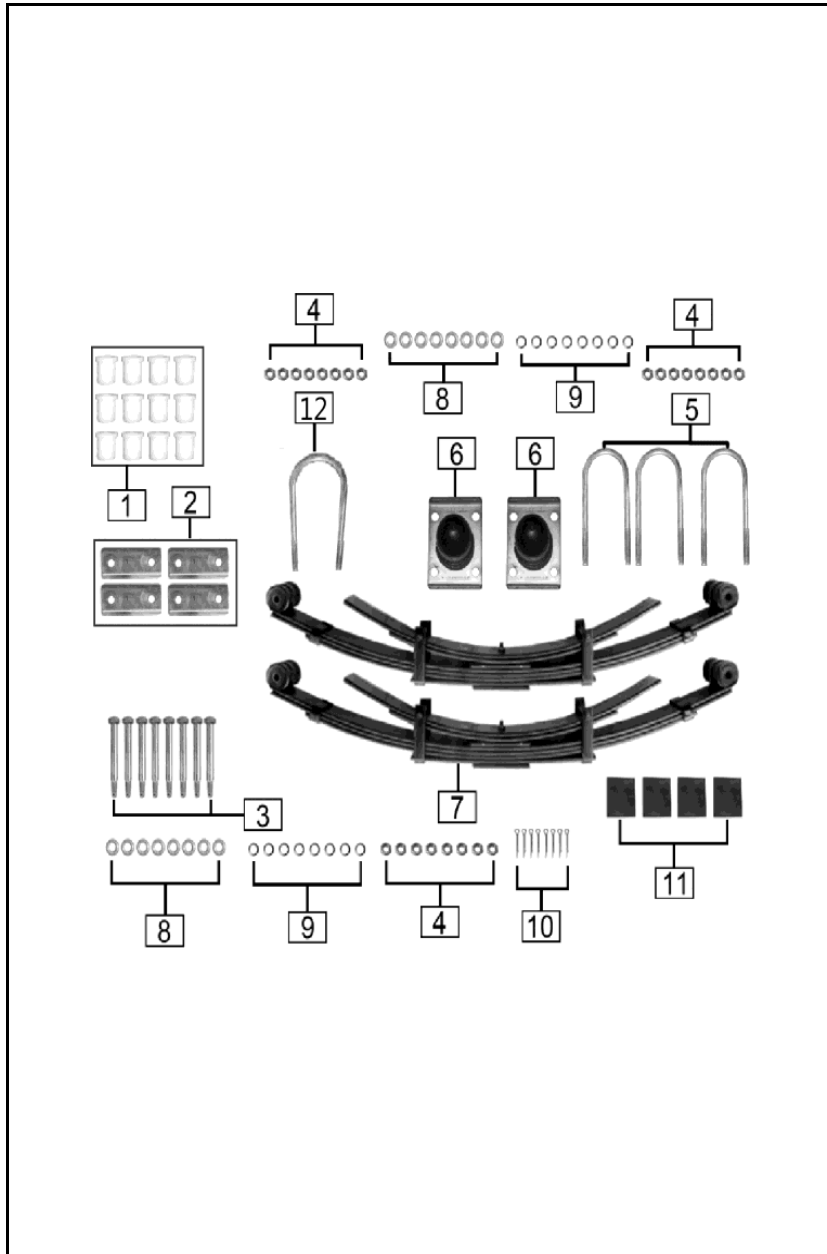

FIG. No.	PARTE N°	DESCRIPCIÓN	CANT.	SAP
1	33004-L1B3-0000	BUJE PLÁSTICO	12	22000181
2	33002-K1S1-01000C	PLATINA	4	22000112
3	B000310112011571C	PERNO M12-115	6	11073135
4	B061700012000061C	TUERCA M12	22	11048217
5	33001-L3L6-00000C	VARILLA DE AJUSTE MUELLE	3	22000111
6	33010-L1D5-00000C	PLATINA VARILLA DE AJUSTE MUELLE	2	22000117
7	33500-L1B3-0000	MUELLE DE AMORTIGUACIÓN	2	22000272
8	B000950012000021C	ARANDELA 12 MM.	16	11048170
9	B0009300120000U1C	ARANDELA DE PRESIÓN 12 MM.	16	11048161
10	B000910002503021C	PIN DE SEGURIDAD 2.5X30	8	11048151
11	33013-L1B3-0000	ANTIVIBRANTE	4	22000188
12	33001-L3L6-01000C	VARILLA DE AJUSTE MUELLE	1	22000113

FIGURA N° 37: CARDAN

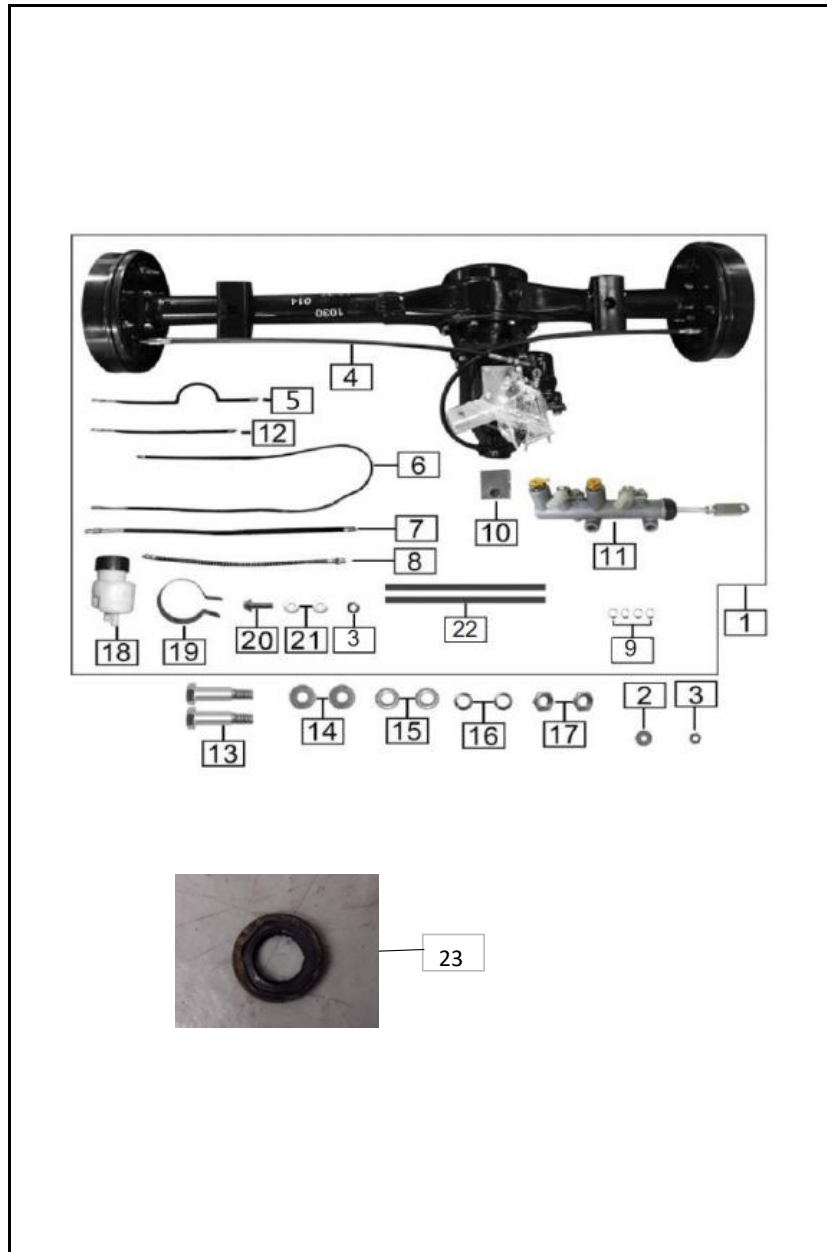

FIG. No.	PARTE N°	DESCRIPCIÓN	CANT.	SAP
1	56300-L3L6-0200	CARDAN COMPLETO	1	22000271
2	B000960208000021C	ARANDELA 8 MM.	1	11048172
3	B061700008000061C	TUERCA M8	3	11048213
4	3824F-L1A8-0000	CABLE DE PARQUEO	1	11048013
5	52177-L3L6-0200	CONDUCTO 555 MM.	1	22000268
6	52177-L3L6-0100	CONDUCTO 1550 MM.	1	22000270
7	52177-L3L6-0000	CONDUCTO 850 MM.	1	22000269
8	52175-L3L6-0000	MANGUERA DE ALTA PRESIÓN	1	22000228
9	19410-L3L6-0000	ABRAZADERA	4	22000233
10	61143-0000-0300	UNIÓN CONDUCTO	1	22000229
11	52160-L3L6-00001C	BOMBA FRENO TRASERO	1	22000225
12	52177-L3L6-0300	CONDUCTO 450 MM.	1	22000267
13	B057830010006571C	TORNILLO 10X65	2	11048209
14	B000960212000021C	ARANDELA 12 MM.	2	11048173
15	B000950010000021C	ARANDELA 10 MM.	2	11048168
16	B0009300100000U1C	ARANDELA DE PRESIÓN 10 MM.	2	11048158
17	B061700010000061C	TUERCA M10	2	11048215
18	52171-L3L6-0000	TANQUE LIQUIDO FRENOS	1	11048031
19	52176-L3L6-0000	ABRAZADERA	1	22000232
20	B057830008002071C	TORNILLO 8X20	2	11048197
21	B000950008000021C	ARANDELA 8 MM.	2	11048166
22	53070-L3L6-0000	MANGUERA	2	22000230
23	56337-L3L6-000001	ARANDELA CONCAVA	1	11084750

FIGURA N° 38: EJE DE TRANSMISIÓN

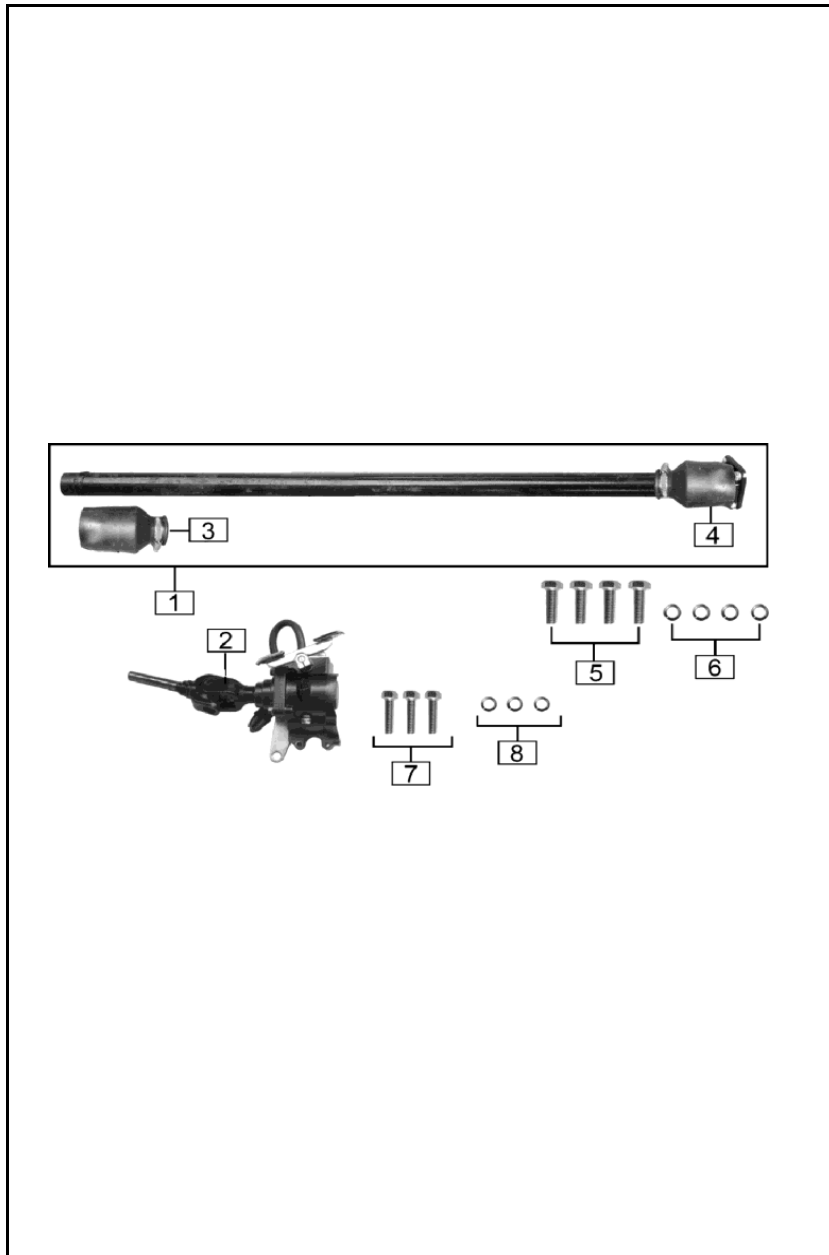

FIG. No.	PARTE N°	DESCRIPCIÓN	CANT.	SAP
1	56200-L3L6-0000	EJE DE TRANSMISION	1	22000234
2	56100-L3L6-0000	SISTEMA DE RESERVA	1	22000177
3	56205-0000-0000	GUARDAPOLVO DEL. EJE TRANSMISION	1	11041602
4	56205-0000-0000	GUARDAPOLVO DEL. EJE TRANSMISION	1	11041602
5	B0578300080025S1C	TORNILLO 8X25	4	11048200
6	B0009300080000U1C	ARANDELA DE PRESION 8 MM.	4	11048157
7	B057830006003571C	TORNILLO 6X35	3	11048192
8	B0009300060000U1C	ARANDELA DE PRESION 6 MM.	3	11048155

FIGURA N° 39: VENTILADOR

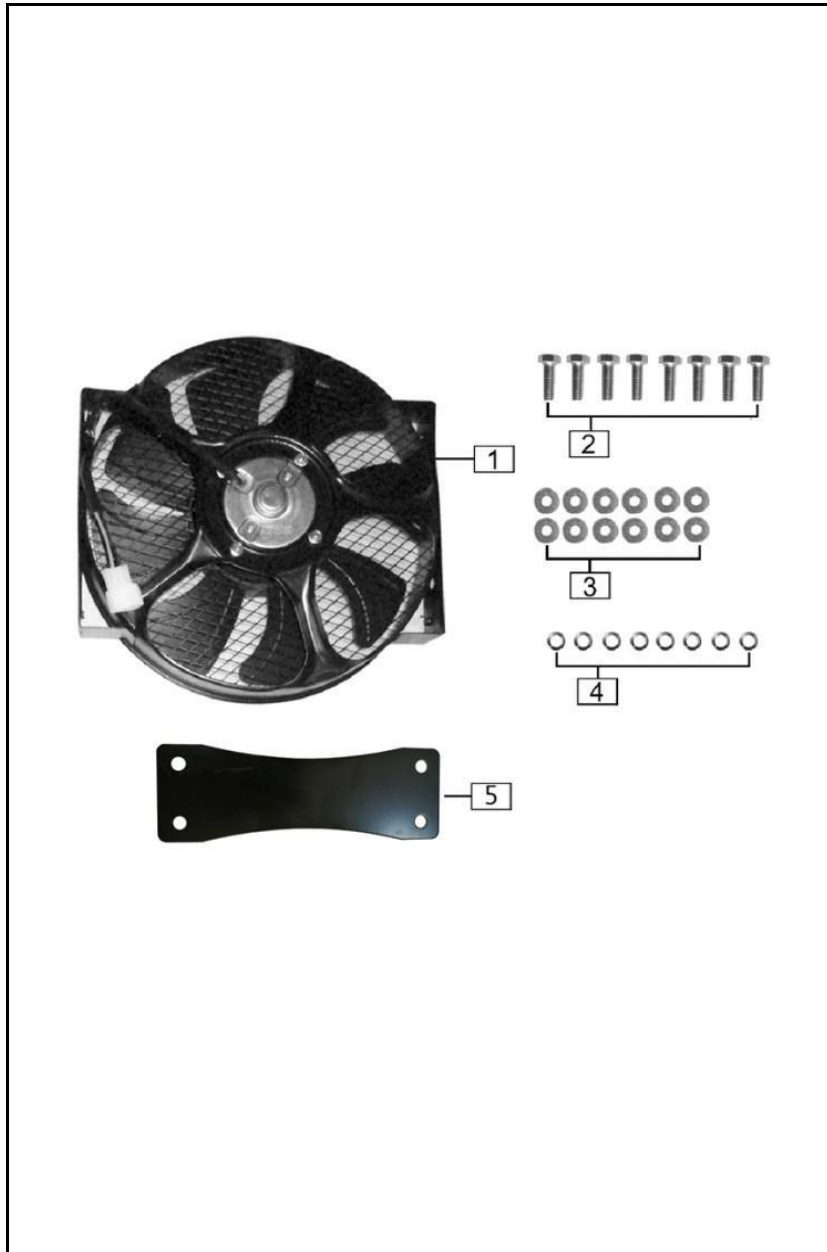

FIG. No.	PARTE N°	DESCRIPCIÓN	CANT.	SAP
1	19100-L1D5-0000	VENTILADOR	1	22000127
2	B057830006002071C	TORNILLO 6X20	8	11048189
3	B000960206000021C	ARANDELA 6 MM.	12	11052679
4	B0009300060000U1C	ARANDELA DE PRESION 6 MM.	8	11048155
5	19309-L3L6-0000	SOPORTE VENTILADOR	2	22000114

FIGURA N° 40: BATERÍA

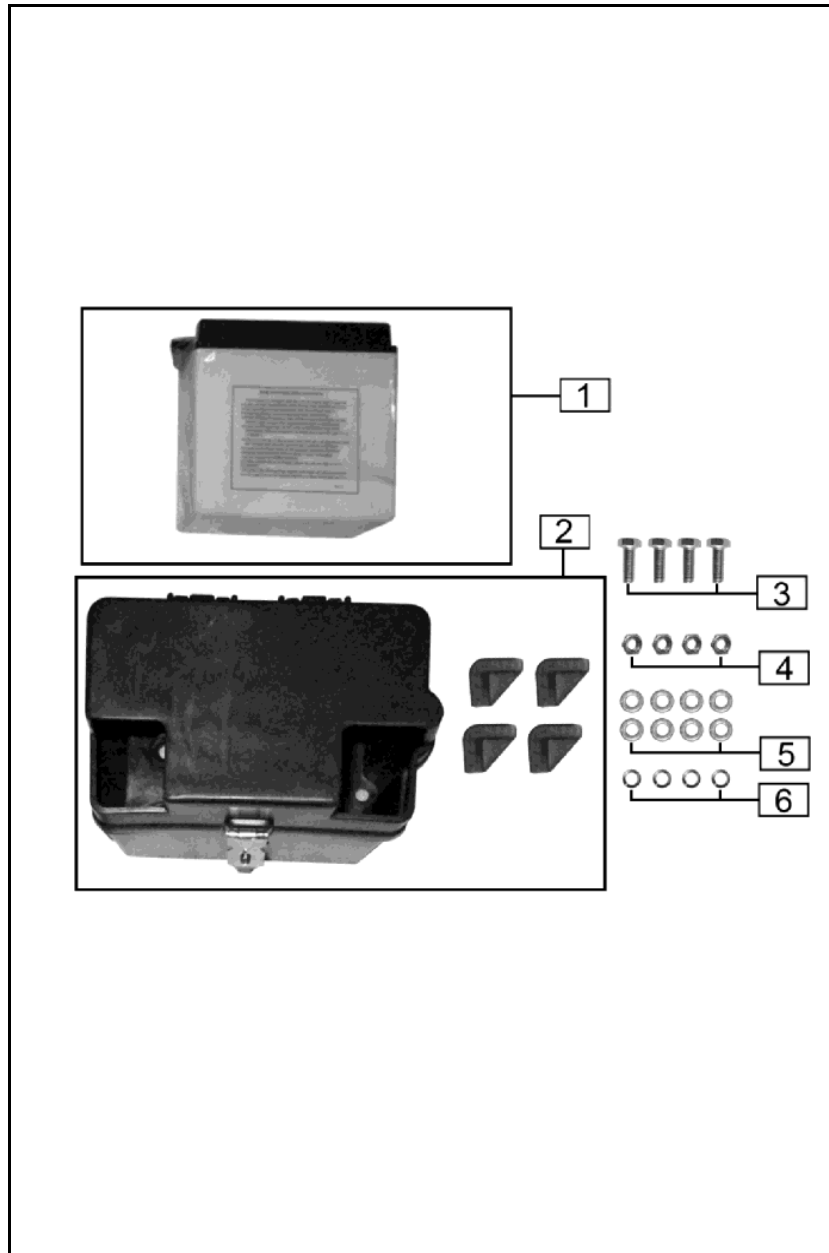

FIG. No.	PARTE N°	DESCRIPCIÓN	CANT.	SAP
1	MTX9A-BS-GEL-PRO	BATERÍA 12V-9AH	1	11034026
2	31410-J1U8-0000	CAJA BATERÍA	1	22000126
3	B057830008002571C	TORNILLO 8X25	4	11048199
4	B061700008000061C	TUERCA M8	4	11048213
5	B000950008000021C	ARANDELA 8 MM.	8	11048166
6	B0009300080000U1C	ARANDELA DE PRESIÓN 8 MM.	4	11048157

FIGURA N° 41: COMPONENTES FRENO TRASERO



FIGURA N° 41: COMPONENTES FRENO TRASERO

FIG. No.	PARTE N°	DESCRIPCIÓN	CANT.	SAP
1	B057830008003070C	TORNILLO 8X30	6	11048201
2	B008940120000N0E	ANILLO RETENEDOR	1	11048181
3	3823Y-L1A8-0000	PIN DE SEGURIDAD	1	11047998
4	71200-6004-RS	RODAMIENTO BOLAS 6004-RS	1	11048083
5	3822Y-L1A8-0000	T APA CAJA DE CAMBIOS	1	11047977
6	3823B-L1A8-0000	EMPAQUE T APA CAJA DE CAMBIOS	1	11041604
7	B057830010004070C	T ORNILLO 10X40	4	11048206
7A	B0009300100000U0C	ARANDELA DE PRESIÓN 10 MM.(NO ILUS)	4	11048158
8	3823C-L1A8-0000	SOPORTE CAJA DE CAMBIOS	1	11047979
9	B057830006002070C	T ORNILLO 6X20	4	11048188
10	3823Z-L1A8-0000	ANILLO RETENEDOR	2	11047999
11	3823D-L1A8-0000	PIÑÓN SATÉLITE CAJA CAMBIOS	2	11047980
12	3820V-L1A8-0000	ARANDELA DE COBRE	2	11047964
13	3820R-L1A8-0000	PIÑÓN PLANETARIO CAJA CAMBIOS	2	11047961
14	3820T-L1A8-0000	EJE PIÑÓN PLANETARIO	1	11047963
15	3820G-L1A8-0000	TAPA ACOPLA EJE RUEDA TRASERO	1	11047957
16	B057830008002070C	T ORNILLO 8X20	14	11048196
16A	38241-L1A8-0000	ARANDELA 8 MM.(NO ILUS)	6	11048001
17	71200-6008	RODAMIENTO 6008	1	11048084
18	38246-L1A8-0000	T ORNILLO EJE TRANSMISIÓN DER.	4	11048005
19	B061700008000060C	TUERCA M8	9	11048212
20	3821F-L1A8-0000	CAMPANA TRASERA	2	11047966
21	38247-L1A8-0000	TUERCA T APÓN CAMPANA TRASERA	4	11048006
22	3822R-L1A8-0000	T ORNILLO DE AJUSTE	1	11047975
23	3822N-L1A8-0000	RESORTE CORTO	1	11047972

FIG. No.	PARTE N°	DESCRIPCIÓN	CANT.	SAP
24	3824E-L1A8-0000	PLATINA SOPORTE	1	11048012
25	3822J-L1A8-0000	CUÑA COMPRESOR	1	11047970
25A	3822G-L1A8-0000	RESORTE COMPRESOR(NO ILUS)	1	11047968
25B	3822H-L1A8-0000	ARANDELA COMPRESOR(NO ILUS)	1	11047969
26	3824C-L1A8-0000	PLATINA SOPORTE	1	11048010
27	3823H-L1A8-0000	BUJE	2	11047984
28	B000910003201620C	PIN DE SEGURIDAD 3.2X16	1	11048153
29	B008820008001420C	PIN PASADOR 8X14	1	11048177
30	3822K-L1A8-0000	RESORTE LARGO	1	11047971
31	3821J-L1A8-010001	BANDAS FRENO TRASERO	4	22000852
32	B057830008002570C	T ORNILLO 8X25	8	11048198
33	3823E-L1A8-0000	GUARDAPOLVO PLATO RUEDA TRASERA	2	11047981
34	3822E-L1A8-0000	CILINDRO FRENO TRASERO	1	11047967
35	3823G-L1A8-0000	PLATO RUEDA DERECHA	1	11047983
36	B057830006001270C	T ORNILLO 6X12	1	11048186
37	71200-6206	RODAMIENTO BOLAS 6206	1	11048087
38	3823J-L1A8-0000	BUJE	2	11047985
39	B0009300080000U0C	ARANDELA 8 MM.(NO ILUS)	23	11048156
40	73517-42557	RETEN 42X55X7	2	11040626
41	3820P-L1A8-0000	EJE DE TRANSMISIÓN DERECHO	1	11047960
42	3820D-L3L6-0000	CARDAN (SOLO)	1	11047955
43	3823F-L1A8-0000	PLATO RUEDA IZQUIERDA	1	11047982
44	38249-L1A8-0000	TUERCA T APÓN CAMPANA TRASERA	5	11048008
45	3820X-L1A8-0000	EJE TRANSMISIÓN IZQUIERDO	1	11047965
46	38248-L1A8-0000	T ORNILLO EJE TRANSMISIÓN IZQ.	5	11048007

FIGURA N° 41: COMPONENTES FRENO TRASERO

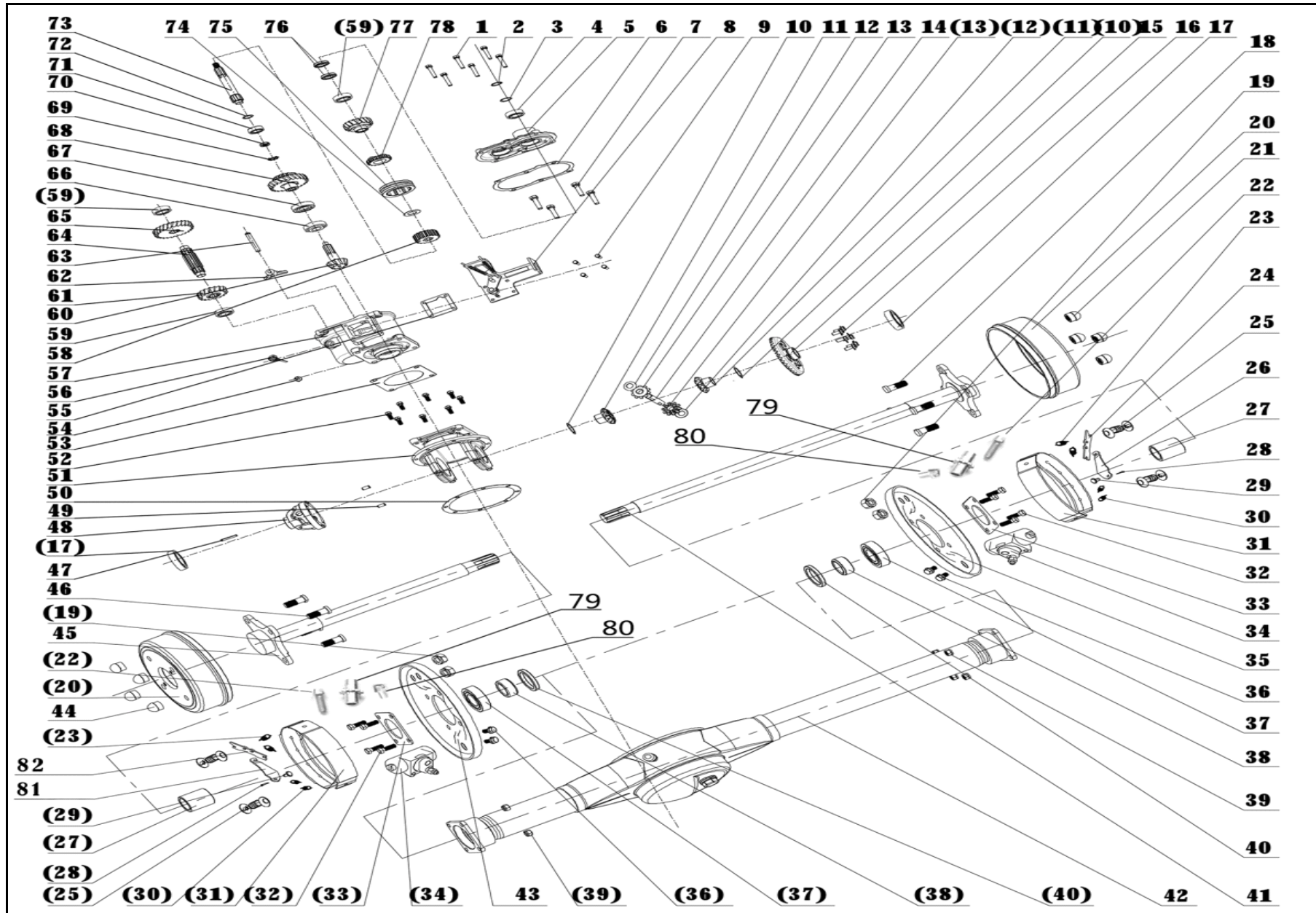
FIG. No.	PARTE N°	DESCRIPCIÓN	CANT.	SAP
47	3820F-L1A8-0000	PIN DE SEGURIDAD 5X40	1	11047956
48	3820S-L1A8-0000	ACOPLE DIFERENCIAL	1	11047962
49	B0011900080018000	PIN PASADOR 8X18	2	11048174
50	3823K-L1A8-0000	EMPAQ ACOPL EJES TRASE	1	11040628
51	3820H-L1A8-0000	ACOPLE EJES TRASEROS	1	11047958
52	B0009300060000U0C	ARANDELA DE PRESIÓN 6 MM.(NO ILUS)	5	11048154
53	38260-L1A8-0000	EMPAQUE CAJA CAMBIOS	1	11041605
54	B057830008001270C	T ORNILLO 8X12	1	11048194
54A	B00095000800002	ARANDELA 8 MM.(NO ILUS)	1	11048164
55	3823L-L1A8-0000	CINTA DE PROTECCIÓN	1	11047986
56	3823M-L1A8-0000	T APÓN NIVEL ACEITE	1	11047987
56A	B03452011322650	ANILLO RETENEDOR(NO ILUS)	1	11048182
57	3822Z-L1A8-0000	CAJA DE CAMBIOS TRAS.	1	11047978
58	3823N-L1A8-0000	PIÑÓN CAJA CAMBIOS TRAS.	1	11047988
59	71200-6004	RODAMIENTO BOLAS 6004	1	11048082
60	3820L-L1A8-0000	PIÑÓN CAJA CAMBIOS TRAS.	1	11047959
61	3823P-L1A8-0000	PIÑÓN HELICOIDAL CAJA CAMBIOS TRAS.	1	11047989
62	3823Q-L1A8-0000	HORQUILLA CAJA CAMBIOS TRAS.	1	11047990
63	3823R-L1A8-0000	EJE HORQUILLA CAJA CAMBIOS TRAS.	1	11047991
64	3823S-L1A8-0000	EJE CAJA CAMBIOS TRAS.	1	11047992
65	3823T-L1A8-0000	PIÑÓN HELICOIDAL CAJA CAMBIOS TRAS.	1	11047993
66	71200-30304	RODAMIENTO BOLAS 30304	1	11048079
67	71200-32006	RODAMIENTO BOLAS 32006	1	11048080
68	3823U-L1A8-0000	PIÑÓN DOBLE CAJA CAMBIOS TRAS.	1	11047994
69	38242-L1A8-0000	ARANDELA 12 MM.	1	11048002

FIG. No.	PARTE N°	DESCRIPCIÓN	CANT.	SAP
70	B008120012000070E	TUERCA M12	1	11048175
71	71200-6003	RODAMIENTO BOLAS 6003	1	11048081
72	38243-L1A8-0000	ARANDELA DE SELLADO	1	11048003
73	3820B-L1A8-0000	EJE CAJA CAMBIOS TRAS.	1	11047954
74	38244-L1A8-0000	ARANDELA DE SELLADO	1	11048004
75	3823V-L1A8-0000	BUJE CAJA CAMBIOS TRAS.	1	11047995
76	73517-20357	RETEN 20X35X7	2	11048113
77	3823W-L1A8-0000	PIÑÓN HELICOIDAL CAJA CAMBIOS TRAS.	1	11047996
78	3823W-L1A8-0000	PIÑÓN HELICOIDAL CAJA CAMBIOS TRAS.	1	11047996
79	3822Q-L1A8-0000	VÁLVULA DE AIRE	2	11047974
80	3822P-L1A8-0000	TAPA VÁLVULA DE AIRE	2	11047973
81	3824B-L1A8-0000	PLATINA SOPORTE	1	11048009
82	3824D-L1A8-0000	PLATINA SOPORTE	1	11048011
83	3822T-L1A8-0000	PLATINA SOPORTE(NO ILUS)	2	11047976

FIGURA N° 42: CAJA REVERSA (1/2)

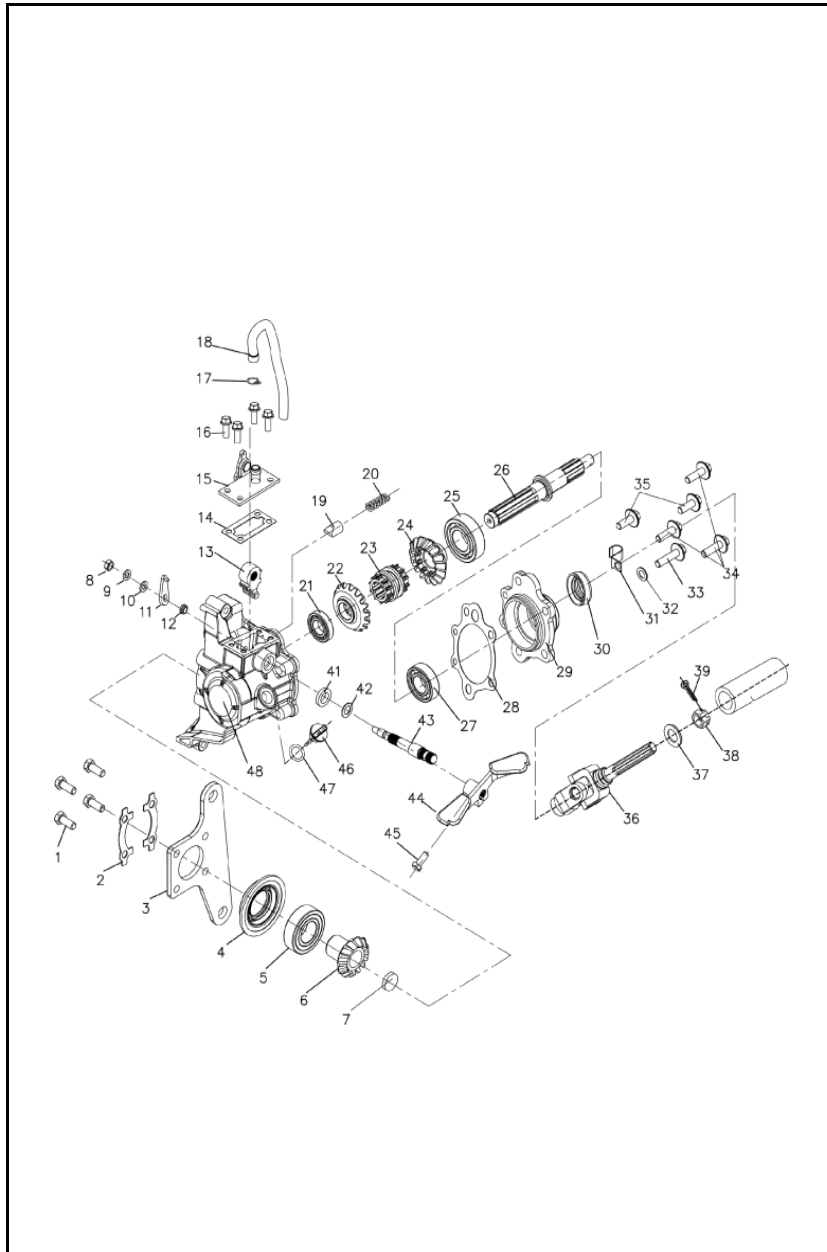

FIG. No.	PARTE N°	DESCRIPCIÓN	CANT.	SAP
1	B057830008002070C	TORNILLO 8X20	4	11048196
2	3823Z-L3L6-0000	PLATINA DE AJUSTE	1	11048000
3	7350S-L1A8-0000	SOPORTE CAJA REVERSA	1	11048104
4	7351Y-L3L6-0000	GUARDAPOLVO	1	11041606
5	71200-6205-2RS	RODAMIENTO BOLAS 6206-2RS	1	11048086
6	7350N-L3L6-0000	PIÑÓN REVERSA (12T)	1	11048103
7	43109-L3L6-0000	TAPÓN	1	11048020
8	B061700006000060C	TUERCA M6	1	11048210
9	B0009300060000U0C	ARANDELA DE PRESIÓN 6 MM.	1	11048154
10	B000950006000020C	ARANDELA 6 MM.	1	11048162
11	7351E-L3L6-0000	PLATINA	1	11048117
12	23258-L3L6-0000	ANILLO RETENEDOR	1	11047930
13	7351B-L3L6-0000	HORQUILLA CAMBIO MARCHA	1	11048116
14	7351A-L3L6-0000	EMPAQUE TAPA CAJA REVERSA	1	11048115
15	7350V-L3L6-0000	TAPA CAJA REVERSA	1	11048106
16	B166740105001270C	TORNILLO 5X12	4	11048220
17	7350W-L3L6-0000	ABRAZADERA	1	11048107
18	7350X-L3L6-0000	MANGUERA DE RESPIRACIÓN	1	11048108
19	7351J-L3L6-0000	LEVA REVERSA	1	11048119
20	7351K-L3L6-0000	RESORTE LEVA REVERSA	1	11048120
21	71200-16003	RODAMIENTO BOLAS	1	11048078
22	7350K-L3L6-0000	PIÑÓN SATÉLITE (15T)	1	11048101
23	7350J-L3L6-0000	PIÑÓN PLANETARIO (10T)	1	11048100
24	7350H-L3L6-0000	PIÑÓN SATÉLITE (15T)	1	11048099
25	71200-6205	RODAMIENTO BOLAS 6205	1	11048085

FIGURA N° 42: CAJA REVERSA (2/2)

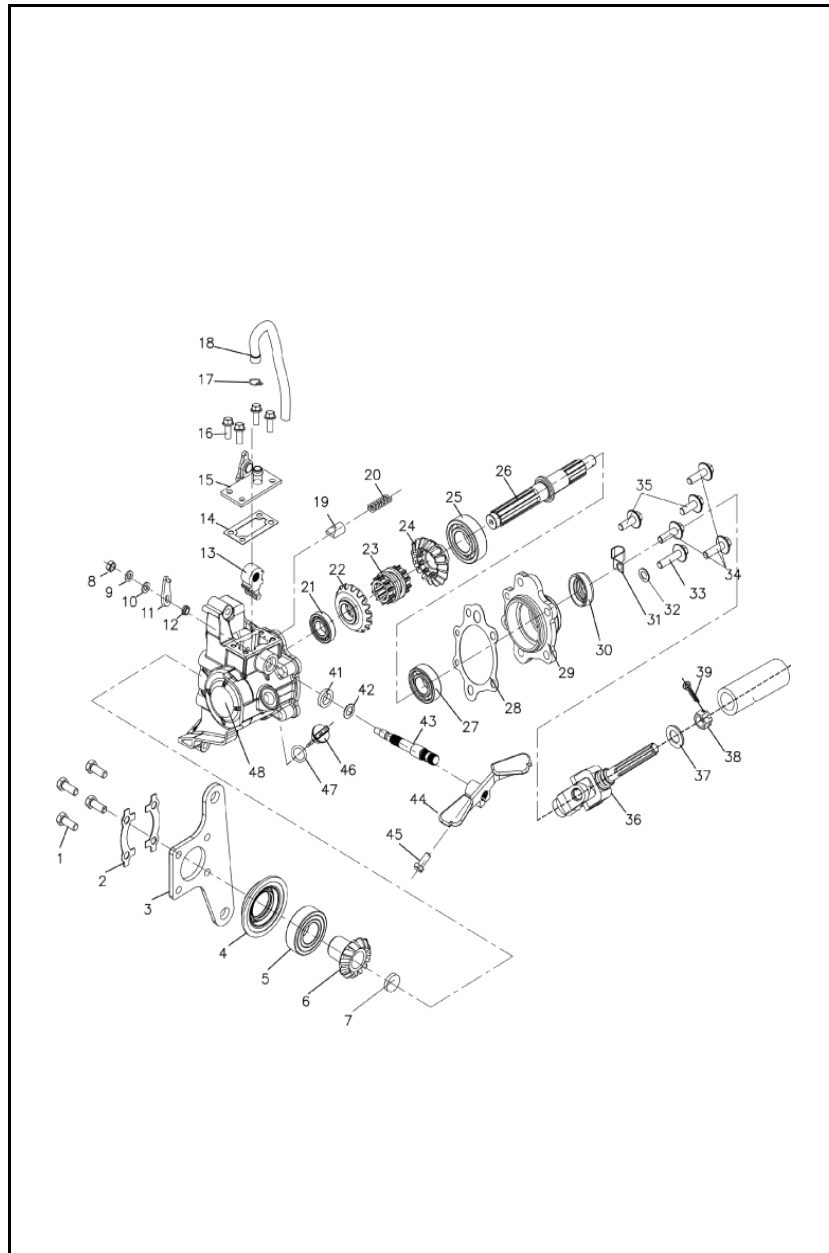

FIG. No.	PARTE N°	DESCRIPCIÓN	CANT.	SAP
26	7351H-L3L6-0000	EJE REVERSA	1	11048118
27	71200-6004	RODAMIENTO BOLAS 6004	1	11048082
28	7350G-L3L6-0000	EMPAQUE COMPLEMENTO CAJA REVERSA	1	11041607
29	7350F-L3L6-0000	COMPLEMENTO CAJA REVERSA	1	11048098
30	73517-L3L6-0000	RETEN	1	11048114
31	7350Y-L3L6-0000	ABRAZADERA	1	11048109
32	7351T-L3L6-0000	ARANDELA NYLON	1	11048122
33	B166740108002570C	TORNILLO 8X25	1	11048223
34	B166740108002070C	TORNILLO 8X20	3	11048222
35	B166740106001870C	TORNILLO 6X18	2	11048221
36	7351Q-L3L6-0000	EJE ACCIONADOR REVERSA		11048121
37	B000950012000020C	ARANDELA 12 MM.	1	11048169
38	B0618100120000U	TUERCA M12	1	11048219
39	B000910003002520C	PIN DE SEGURIDAD 3X25	1	11048152
40	7350L-L3L6-0000	CAJA REVERSA	1	11048102
41	73517-10164	ANILLO RETENEDOR	1	11048112
42	7350Z-L3L6-0000	ARANDELA 10 MM.	1	11048110
43	7350E-L3L6-0000	EJE REVERSA	1	11048097
44	73511-L3L6-0000	PEDAL REVERSA	1	11048111
45	B057830006002070C	TORNILLO 6X20	1	11048188
46	7350U-L3L6-0000	TAPÓN NIVEL ACEITE	1	11048105
47	B03452011322650	ANILLO RETENEDOR	1	11048182

FIGURA N° 43: CAJA DE HERRAMIENTAS - ESTUCHE HERRAMIENTAS

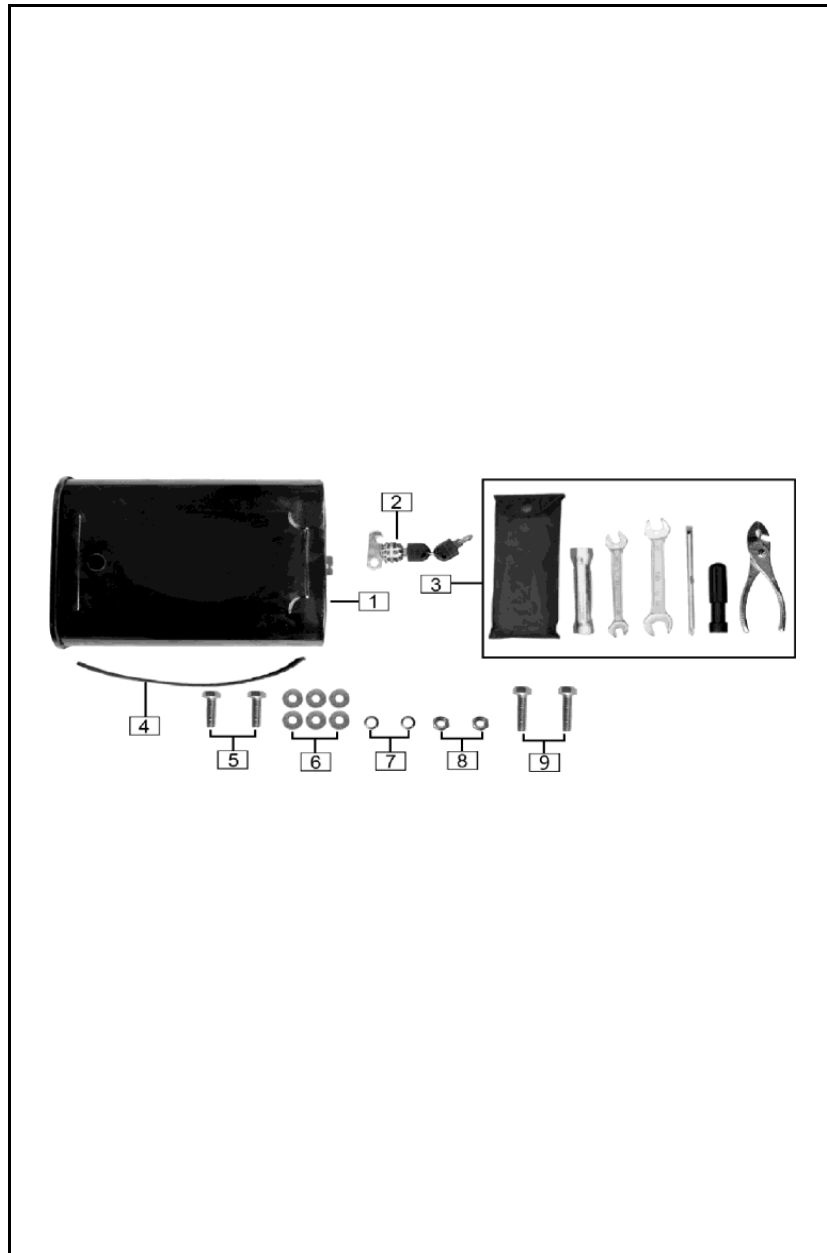

FIG. No.	PARTE N°	DESCRIPCIÓN	CANT.	SAP
1	64070-L3L6-000065	CAJA DE HERRAMIENTAS	1	22000257
2	64370-L3L6-0000	SEGURO CAJA DE HERRAMIENTAS	1	22000296
3	06000-0000-0200	ESTUCHE DE HERRAMIENTAS	1	22000160
4	6407A-0000-0000	EMPAQUE CAJA DE HERRAMIENTAS	1	22000214
5	B057830008002071C	TORNILLO 8X20	2	11048197
6	B000960208000021C	ARANDELA 8 MM.	6	11048172
7	B0009300080000U1C	ARANDELA DE PRESIÓN 8 MM.	2	11048157
8	B061700008000061C	TUERCA M8	2	11048213
9	B057830008002571C	TORNILLO 8X25	2	11048199



FIGURA N° 44: CALCOMANÍAS

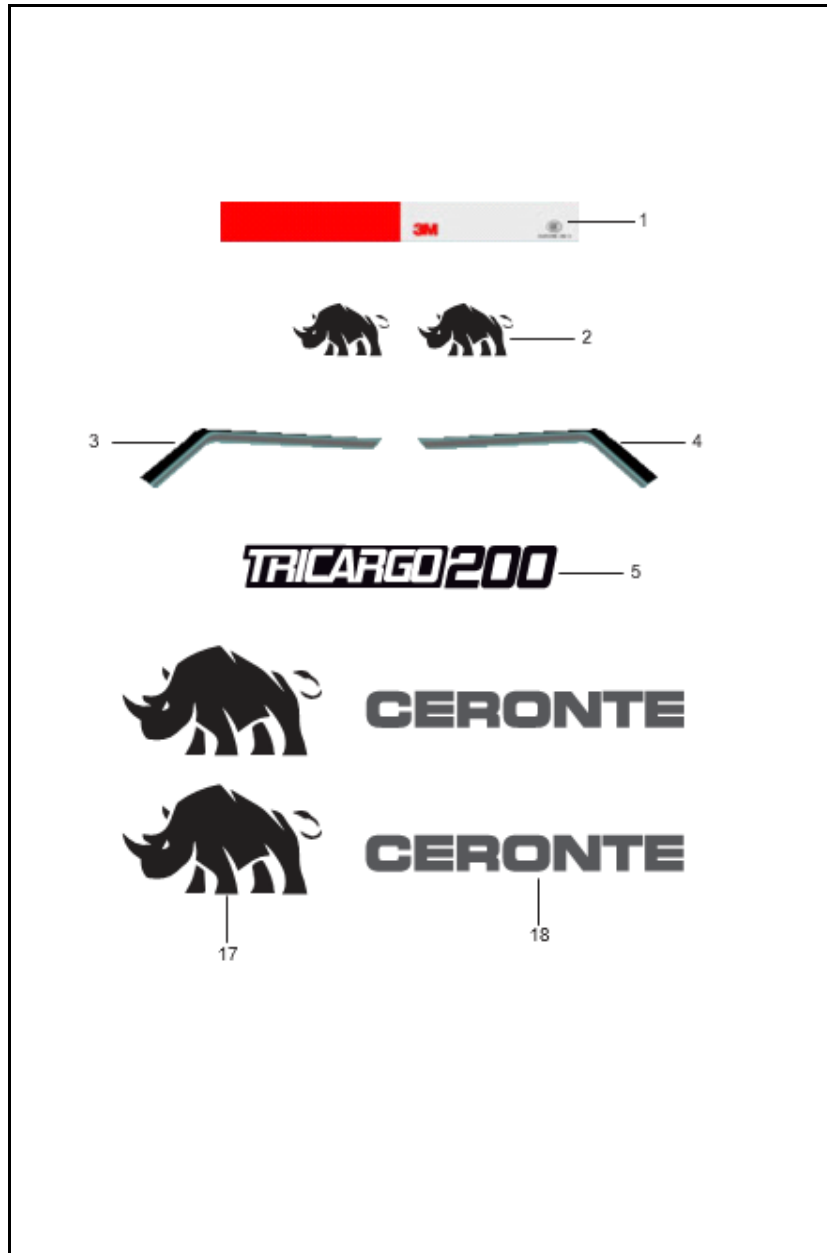

FIG. No.	PARTE N°	DESCRIPCIÓN	CANT.	SAP
1	01160-0000-0000	CALCOMANÍA REFLECTIVA	8	22000242
2	63033-L3L6-490000	CALCOMANÍA SUP TANQ GASOLINA(GRIS)	2	11052703
	63033-L3L6-500000	(NEGRO)	2	11052707
3	63034-L3L6-490000	CALCOMA INF DER TANQ GASOLIN(BLANCO)	1	11052704
	63034-L3L6-500000	(NEGRO)	1	11052708
	63034-L3L6-510000	(GRIS)	1	11052711
4	63032-L3L6-490000	CALCOMA INF IZQ TANQUE GASOLINA(BLANCO)	1	11052705
	63032-L3L6-500000	(NEGRO)	1	11052709
	63032-L3L6-510000	(GRIS)	1	11052712
5	63038-L3L6-490000	CALCOMANÍA TAPA LATERAL(BLANCO)	2	11052706
	63038-L3L6-500000	(NEGRO)	2	11052710
	63038-L3L6-510000	(GRIS)	2	11052713
17	6300C-L3L6-0100	CALCOMANÍA VOLCÓ LOGO CERONTE	2	22000243
18	6300C-L3L6-0300	CALCOMANÍA VOLCÓ "CERONTE"	2	22000244

LISTA DE KITS

CODIGO DEL KIT	DESCRIPCIÓN	SAP	CONTENIDO DEL KIT	CANTIDAD
21016855	KIT CILINDROS	11047884	CILINDRO	1
		11047792	PISTON	1
		11047794	ANILLOS	1
		11047793	PASADOR PISTON	1
		11047782	PIN PISTON	2
		11041618	EMPAQUE CILINDRO	1
		11041617	EMPAQUE CULATA	1
22000163	KIT CUNAS	22000163	RODAMIENTO 30205	2
21016905	KIT DISCOS CLUTCH	22000842	DISCO DE CLUTCH	4
		11040621	DISCO DE CLUTCH	2
		11040620	SEPARADOR CLUTCH	5
21016934	KIT EMPAQUES	11041594	RETEN VALVULA	2
		11041617	EMPAQUE CULATA	1
		11041618	EMPAQUE CILINDRO	1
		11041619	EMPAQUE CARCASA CLUTCH	1
		11041620	EMPAQUE CUBIERTA VOLANTE	1
		11041616	EMPAQUE TAPA CULATA	1
		11041622	EMPAQUE CENTRO MOTOR	1
		22000221	EMPAQUE TUBO MOFLE	1
21016963	KIT PISTON	11047792	PISTON	1
		11047794	ANILLOS	1
		11047793	PASADOR PISTON	1
		11047782	PIN PISTON	2
21016971	KIT VALVULAS	11047844	VALVULA ADMISION	1
		11047887	VALVULA ESCAPE	1
		11041594	RETEN VALVULA	2

FICHA TÉCNICA TRICARGO 200

CARACTERÍSTICA	UNIDAD
Motor	4 Tiempos, Monocilíndrico OHC
Diámetro x Carrera	63.5 mm X 62.2 mm
Indicé de Compresión	8.5 - 9.3 : 1
Potencia Máxima	13.4 HP @ 7500 RPM
Torque Máximo	13.5 NM @ 6500 RPM
Bujía	NGK D8EA
Arranque	Eléctrico y Pedal
Transmisión	Mecánica de 5 Marchas + Bostear
Sistema de Alimentación	Carburador
Lubricación	Forzada, Bomba Trocoidal
Capacidad máxima de carga	480 Kg.
FRENOS	
Freno Delantero	Disco
Freno Trasero	Campana
SUSPENSION	
Suspensión Delantera	Telescópica Hidráulica
Suspensión Trasera	Muelle de Amortiguación
CAPACIDAD DEL TANQUE	
Lleno	16 Litros (4.22 Gal.)
Combustible	Gasolina
LLANTAS	
Llanta Delantera	4.50 - R12
Llanta Trasera	4.50 - R12
SISTEMA ELECTRICO	
Farola	LED
Luz Freno	LED
Luces Direccionales	LED
Luz Velocímetro	12V-1.7W
Pito	12V-1.5AH
Batería	12V-9AH
Sistema de Ignición	C.D.I
DIMENSIONES	
Largo x Ancho x Alto	3320 mm x 1260 mm x 1410 mm
Distancia Entre Ejes	2300 mm

TRICARGO 200

